

Distributed Hierarchical Processing in the Primate Cerebral Cortex

Daniel J. Felleman¹ and David C. Van Essen²

¹ Department of Neurobiology and Anatomy, University of Texas Medical School, Houston, Texas 77030, and ² Division of Biology, California Institute of Technology, Pasadena, California 91125

In recent years, many new cortical areas have been identified in the macaque monkey. The number of identified connections between areas has increased even more dramatically. We report here on (1) a summary of the layout of cortical areas associated with vision and with other modalities, (2) a computerized database for storing and representing large amounts of information on connectivity patterns, and (3) the application of these data to the analysis of hierarchical organization of the cerebral cortex. Our analysis concentrates on the visual system, which includes 25 neocortical areas that are predominantly or exclusively visual in function, plus an additional 7 areas that we regard as visual-association areas on the basis of their extensive visual inputs. A total of 305 connections among these 32 visual and visual-association areas have been reported. This represents 31% of the possible number of pathways if each area were connected with all others. The actual degree of connectivity is likely to be closer to 40%. The great majority of pathways involve reciprocal connections between areas. There are also extensive connections with cortical areas outside the visual system proper, including the somatosensory cortex, as well as neocortical, transitional, and archicortical regions in the temporal and frontal lobes. In the somatosensory/motor system, there are 62 identified pathways linking 13 cortical areas, suggesting an overall connectivity of about 40%. Based on the laminar patterns of connections between areas, we propose a hierarchy of visual areas and of somatosensory/motor areas that is more comprehensive than those suggested in other recent studies. The current version of the visual hierarchy includes 10 levels of cortical processing. Altogether, it contains 14 levels if one includes the retina and lateral geniculate nucleus at the bottom as well as the entorhinal cortex and hippocampus at the top. Within this hierarchy, there are multiple, intertwined processing streams, which, at a low level, are related to the compartmental organization of areas V1 and V2 and, at a high level, are related to the distinction between processing centers in the temporal and parietal lobes. However, there are some pathways and relationships (about 10% of the total) whose descriptions do not fit cleanly into this hierarchical scheme for one reason or another. In most instances, though, it is unclear whether these represent genuine exceptions to a strict hierarchy rather than inaccuracies or uncertainties in the reported assignment.

During the past decade, there has been an explosion of information about the organization and connectivity of sensory and motor areas in the mammalian cerebral cortex. Many laboratories have concentrated their efforts on the visual cortex of macaque monkeys, whose superb visual capacities in many ways rival those of humans. In this article, we survey recent progress in charting the layout of different cortical areas in the macaque and in analyzing the hierarchical relationships among these areas, particularly in the visual system.

The original notion of hierarchical processing in the visual cortex was put forward by Hubel and Wiesel (1962, 1965) to account for a progressive increase in the complexity of physiological receptive field properties in the cat visual cortex. In particular, they suggested that a serial, feedforward scheme could account for the generation of simple cells from LGN inputs, and complex cells, in turn, from simple cells. Likewise, the properties of hypercomplex cells and even "higher-order hypercomplex cells" were attributed to inputs from their immediate predecessors. However, the pure form of this hypothesis is difficult to reconcile with the finding of highly reciprocal connectivity and parallel channels discovered in more recent studies of the visual pathway (cf. Rockland and Pandya, 1979; Stone et al., 1979; Lennie, 1980; Lennie et al., 1990; Shapley, 1990). On the other hand, there is no a priori reason to restrict the notion of hierarchical processing to a strictly serial sequence. In general, any scheme in which there are well-defined levels of processing can be considered hierarchical.

The notion that anatomical criteria could be used to delineate a hierarchy of cortical areas first received detailed scrutiny about a decade ago (Rockland and Pandya, 1979; Friedman, 1983; Maunsell and Van Essen, 1983). Since this hypothesis was last reviewed systematically (Van Essen, 1985), the number of identified visual areas and identified connections has increased greatly. In addition, 2 recent studies (Anderson et al., 1990; Boussaoud et al., 1990) have proposed hierarchical relationships for parietal, temporal, and frontal areas that are largely, but not completely, consistent with one another and with our previous schemes. Here, we provide a critical examination of the degree to which the entire ensemble of available data fits into an overall hierarchical scheme. We also review the evidence that the principle of hierarchical

organization applies to other functional modalities and to other species besides macaques.

A related theme in our analysis concerns the nature of concurrent processing streams in the visual cortex. These streams are linked at the input side to specific subcortical inputs from the magnocellular (M) and parvocellular (P) layers of the LGN (cf. Blasdel and Lund, 1983; Hubel and Livingstone, 1987) and, at the output side, to functionally distinct regions of the parietal and temporal lobes (Ungerleider and Mishkin, 1982; Desimone and Ungerleider, 1989). Our analysis will emphasize that, on the one hand, there is considerable segregation of information flow throughout the visual pathway; on the other hand, there is also substantial intermixing and cross talk between streams at successive stages of processing. It is likely that these complexities in the anatomical circuitry reflect the multiplicity of computational strategies needed for efficient visual function (DeYoe and Van Essen, 1988).

Subdivisions and Interconnections of the Visual Cortex

A Cortical Map

Our primary format for illustrating the location of different visual areas involves the use of 2-D cortical maps that are generated from contours of layer 4 in a series of regularly spaced histological sections (Van Essen and Zeki, 1978; Van Essen and Maunsell, 1980). Previous summary maps showing the distribution of areas (Van Essen and Maunsell, 1983; Van Essen, 1985) were based on section drawings from a hemisphere published by Brodmann (1905). That map was not especially accurate, however, because of the large and somewhat nonuniform spacing between sections, and no scale was provided. We have therefore generated a complete map from a hemisphere used in a previous study from this laboratory, in which information about the pattern of interhemispheric connections and about cortical myeloarchitecture was available for identifying certain visual areas (Van Essen et al., 1986). Figure 1 shows the overall layout of the map, including the section contours upon which the map was based (thin lines; 2-mm spacing between sections), the location of cortex within sulci (shading), and the position of the fundus of each sulcus (dashed lines). As in previous cortical maps, it was necessary to introduce a few cuts, or discontinuities, to prevent serious distortions in the representation, and these are indicated by heavy solid lines along the perimeter. In addition to the obvious cut that surrounds area V1 (the elliptical region on the left), there are 2 smaller discontinuities, one along the ventrolateral side of the frontal lobe (upper right), and the other at the temporal pole (lower right). The remainder of the perimeter of the map represents intrinsic borders between the cortex and various noncortical structures (e.g., the dentate gyrus, amygdalar nuclei, and corpus callosum). This map also differs from its predecessors in that it contains the entirety of the cerebral cortex, including archicortical, paleocortical, and transitional regions, as well as the standard 6-layered neocortex.

Visual Areas

Our current understanding of the layout of different visually related areas is indicated by the color-coded scheme in Figure 2. Altogether, there are 32 separate neocortical areas that are implicated in visual processing, based on the occurrence of visually responsive neurons and/or the presence of major inputs from known visual areas. Each of these visual areas is shaded with a different color. The overall extent of the visual cortex corresponds closely to the visually responsive regions identified in the 2-deoxyglucose study of Macko and Mishkin (1985). However, not all of these areas are exclusively visual in function. Nonvisual contributions include inputs from other sensory modalities (especially auditory and somatosensory), visuomotor activity (i.e., related to eye movements), and attentional or cognitive influences (cf. Andersen, 1987; Maunsell and Newsome, 1987; Goldman-Rakic, 1988; Desimone and Ungerleider, 1989). We have drawn a distinction between 25 areas that appear to be predominantly or exclusively visual and another 7 neocortical areas that are less intimately linked to vision and will be considered visual-association areas. This is unlikely to reflect a strict dichotomy, though, and there may well be a continuum in the degree to which various areas are selectively involved in visual processing.

There are 9 visual areas in the occipital lobe, which are shaded in purple, blue, and reddish hues in Figure 2. The 10 visual areas of the parietal lobe (1 of which is associational) are in shades of yellow, orange, or light brown; the 11 areas of the temporal lobe are in various shades of green; and the 2 visual-association areas of the frontal lobe are in dark shades of brown. The criteria used in identifying these areas are discussed in detail below.

On the remainder of the cortical map, various functional or regional domains are delimited in black and white by heavy outlines. These include somatosensory, auditory, motor, olfactory, gustatory, subicular, hippocampal, entorhinal, retrosplenial, and cingulate regions, plus medial, dorsal, lateral, and orbital regions of the prefrontal cortex. Most of these regions have been further subdivided into specific cortical areas, indicated by fine lines, on the basis of cortical architecture and/or connectivity. Many of these areas are denoted by the same type of numbering scheme promulgated by Brodmann (1905). However, in many instances, we have used areal identifications from more recent studies that differ substantially from Brodmann's original scheme. (This can be seen by comparing Fig. 2 of the present study with Fig. 9 of Van Essen and Maunsell, 1980).

The demarcation of areal boundaries on the cortical map involved several stages. As noted, a few visual areas were explicitly identified by architectonic criteria in the hemisphere from which the map was made, and the locations of several additional areas were constrained by the pattern of interhemispheric connections that had been determined in this hemisphere. For the remaining areas, it was necessary to transpose boundaries not only from a different brain,

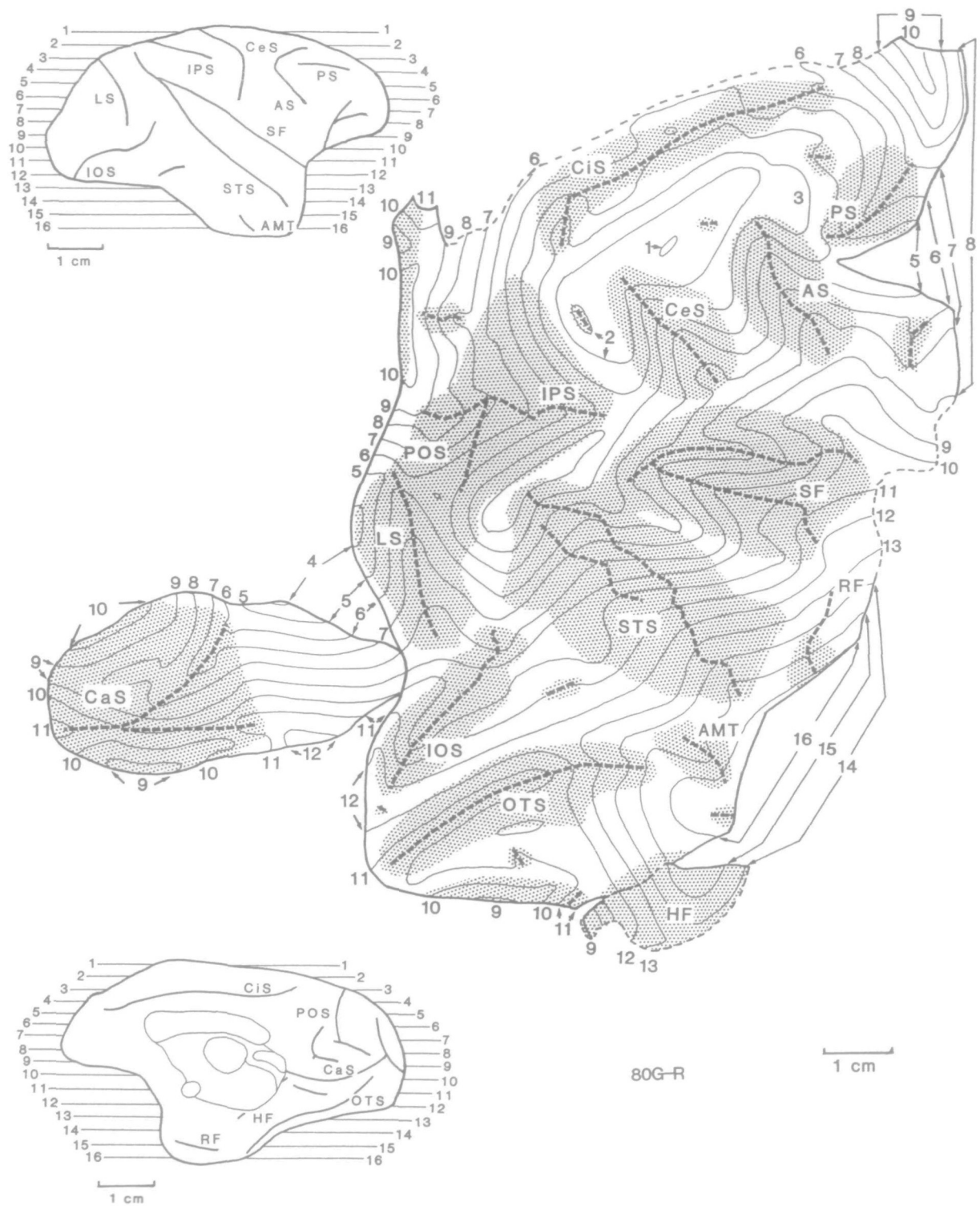

Figure 1. A 2-D map of cerebral cortex in macaque monkey, prepared by the method of Van Essen and Maunsell (1980). *Fine solid lines* represent the contours of layer 4 from a series of 16 horizontal sections taken at 2-mm intervals through the cortex. *Numbers* along the margins of the map correspond to the different section levels indicated in the lateral (*upper left*) and medial (*lower left*) views of the hemisphere. *Shading* indicates cortex lying within various sulci, and the fundus of each sulcus is indicated by *heavy dashed lines*. *Solid lines* along the perimeter of the map indicate regions where artificial cuts have been made to reduce distortions. *Dashed lines* along the perimeter represent the margins of the cortex, where it adjoins various noncortical structures: the corpus callosum/induseum griseum (*top*), olfactory tubercle and amygdalar nuclei (*right*), and dentate gyrus of the hippocampus (*bottom*). The scale on the map has been adjusted to correct for the estimated 16% shrinkage that occurs during histological processing (cf. Van Essen and Maunsell, 1980; Van Essen et al., 1986). *AMT*, anterior middle temporal sulcus; *AS*, arcuate sulcus; *CaS*, calcarine sulcus; *CeS*, central sulcus; *CIS*, cingulate sulcus; *HF*, hippocampal fissure; *IOS*, inferior occipital sulcus; *IPS*, intraparietal sulcus; *LS*, lunete sulcus; *OTS*, occipitotemporal sulcus; *POS*, perieto-occipital sulcus; *PS*, principal sulcus; *RF*, rhinal fissure; *SF*, sylvian fissure; *STS*, superior temporal sulcus.

but usually from a different type of representation as well, because the best available information on areal boundaries, in many cases, was on a drawing of a brain or on a series of brain sections cut at a different angle than the horizontal plane used for our map.¹

Table 1 provides additional information pertaining to the identification and characterization of different visual areas. The areas are grouped according to their geographic location in different lobes (column 1). Columns 2 and 3 give the acronyms and full-length names, respectively, that we prefer for each area. Column 4 provides information about the degree of topographic organization, rated on a scale of 1–4 (see below). It also identifies the visual-association areas alluded to above. Column 5 provides a measure of the confidence with which different areas have been identified, as discussed below. Column 6 provides 1 or more references that have been particularly useful in determining the extent and the boundaries of each area. These citations do not necessarily reflect either the most recent study or the original study involved in its identification. They are designated by abbreviations based on the first letters of the authors' surnames plus the publication year. A key that links these abbreviations to the standard text citations is given in the table notes. This format, which we will use in other tables as well, provides a compact representation that allows more rapid recognition of specific references than is attainable with a simple numerical listing.

In general, 3 methodological approaches have been most useful in identifying different visual areas: (1) *Connectivity analysis* relies on finding a characteristic pattern of inputs and outputs for each cortical area. This approach has proven useful for nearly all visual areas and is considered in detail below. (2) *Architectonics* relies on a distinctive structure as seen in Nissl, myelin, or other staining techniques. It offers a reliable approach for only a minority of the areas listed in Table 1 and was used to map 3 of the areas (V1, V3, and MT) in the particular hemisphere illustrated in Figure 2. (3) *Topographic organization* relies on an orderly mapping of the visual field in each area, as revealed physiologically or anatomically. About half of the identified visual areas show a measurable degree of topographic organization. However, the precision and orderliness of the visual representation varies widely. As indicated in column 4 of Table 1, we have grouped areas into 4 categories: extremely precise and regular topography (category 1), intermediate resolution (category 2), coarse and irregular (category 3), and finally, little or no discernible topography (category 4). In addition, some visual areas (most notably V3 and VP) contain incomplete representations, including only the superior (S) or inferior (I) contralateral quadrant; nonetheless, several lines of evidence argue that these areas should be considered distinct from one another (cf. Burkhalter et al., 1986). Hence, topographic information, like architectonics, is a valuable tool, but can be inadequate or even misleading when applied in isolation from other approaches.

In addition to these 3 primary methodological approaches, the identification of some areas has been facilitated by information about physiological characteristics, as evidenced by distinctive receptive field properties of neurons, and by examining the behavioral consequences of restricted lesions or focal electrical stimulation. Ideally, each area should be independently identifiable using all 5 of the aforementioned approaches. In practice, however, the identification of most areas is based only on a subset of these approaches, often just 1 or 2 (cf. Van Essen, 1985).

Different cortical areas vary in the reliability with which they have been identified and the precision with which their borders have been mapped, as indicated by the 3 categories of confidence level in column 5 of Table 1. The first 2 categories include areas we consider to have been identified with a reasonably high degree of confidence. Category 1 refers to areas, such as V1 and V2, whose borders have been mapped with considerable precision (usually to within 1–2 mm). Category 2 refers to areas, such as V3A and V4, whose identity is widely accepted but whose borders are known only approximately. Category 3 includes areas whose identification is less secure and more open to debate. This is the largest of the 3 categories, and it signifies that the basic task of determining how the cortex is partitioned into specific areas is by no means complete.

Most regions of the visual cortex have more than 1 name that is in common use. Table 1 provides a partial listing of these alternative terminologies. In dealing with the nomenclature issue, we have drawn a distinction between (1) names that are simply different descriptors for what is clearly the same underlying visual area (e.g., areas 17 vs. V1, V3v vs. VP, and MT vs. V5; column 7), and (2) names that reflect substantially different schemes for partitioning the cortex (column 9). In some cases, the alternative scheme is a more coarse partitioning than the one we prefer (e.g., TEO vs. PITd and PITv). In other cases, the alternative scheme is even more fine grained (e.g., POa–i and POa–e vs. LIP). In still other cases, most notably in the inferotemporal cortex (IT), the relationship between different schemes is more complex and irregular.

Surface Area

Measurements of the surface area of different regions of the cortical map (Table 2) provide useful information about the absolute and relative amounts of cortical machinery devoted to different types of processing. The total extent of the cerebral cortex in this particular hemisphere, after correcting for shrinkage during histological processing, is 10,575 mm², of which 9940 mm² (94%) is neocortex. Besides the neocortex, there are 245 mm² of the hippocampus proper (fields CA1 and CA3, the subiculum and the prosubiculum), 120 mm² of paleocortex (pyriform and periamygdaloid cortex), and 270 mm² of transitional cortex [entorhinal cortex (ER), periallocortex, parasubiculum, presubiculum, and prostriate cortex]. The visual cor-

Table 1
Visual areas in the macaque monkey

Lobe	Area		Topog-raphy*	Confi-dence*	References*
	Acronym	Full Name			
Occipital	V1	Visual area 1	1	1	VNM, '84; VNMB, '86
	V2	Visual area 2	2	1	GGS, '81; VNMB, '86
	V3	Visual area 3	2; I	1	VNMB, '86
	VP	Ventral posterior	2; S	1	NMV, '86
	V3A	Visual area V3A	3	2	VZ, '78; GSG, '88
	V4	Visual area 4	3	2	Z, '78; GSG, '88
	VQT	Ventral occipitotemporal	3; S	3	FDV, '85; VFDOOK, '91
	V4t	V4 transitional	3; I	2	DU, '86; GSG, '88
	MT	Middle temporal	3	1	VMB, '81; DU, '86; MV, '87
Temporal	FST	Floor of superior temporal	4	2	DU, '86
	PITd	Posterior inferotemporal (dorsal)	3	3	VFDOOK, '91
	PITv	Posterior inferotemporal (ventral)	3	3	VFDOOK, '91
	CITd	Central inferotemporal (dorsal)	4	3	VFDOOK, '91
	CITv	Central inferotemporal (ventral)	4	3	VFDOOK, '91
	AITd	Anterior inferotemporal (dorsal)	4	3	VFDOOK, '91
	AITv	Anterior inferotemporal (ventral)	4	3	VFDOOK, '91
	STPp	Superior temporal polysensory (posterior)	4; A	3	BUD, '90
	STPa	Superior temporal polysensory (anterior)	4; A	3	BUD, '90
	TF	TF	4; A	3	VB, '47; SP, '76
	TH	TH	4; A	3	VB, '47; SP, '76
Parietal	MSTd	Medial superior temporal (dorsal)	4	2	KW, '88
	MSTl	Medial superior temporal (lateral)	4	2	KW, '88
	PO	Parieto-occipital	3	2	CGOG, '88
	PIP	Posterior intraparietal	3	2	FBV, '87; CGOG, '88
	LIP	Lateral intraparietal	3	3	AAC, '85; AAES, '90; BAS, '90
	VIP	Ventral intraparietal	3	3	BAS, '90; MV, '83; UD, '86
	MIP	Medial intraparietal	?	3	CGOG, '88
	MDP	Medial dorsal parietal	?	3	CGOG, '88
	DP	Dorsal prelunate	3	3	AAC, '85; MA, '86
	7a	7a	4; A	2	AAC, '85; AAES, '90
Frontal	FEF	Frontal eye field	3; A	2	BGBS, '85; SDGM, '89
	46	46	4; A	3	B, '88; BP, '89

The visual areas in the macaque monkey are grouped according to physical location (column 1) and identified according to acronym, full name, and alternative names. Alternative partitioning schemes for the same region are indicated in column 9, as well.

* Topography refers to degree of topographic organization and is rated according to a qualitative 4-point scale, going from extremely precise (rating 1) to completely nontopographic (rating 4). S and I refer to areas that contain an incomplete representation of superior and inferior quadrants, respectively, and A refers to areas that are associational.

* Confidence refers to the confidence with which each area has been identified and charted and is rated by a qualitative 3-point scale: confident identification and well-defined borders (rating 1), confident identification but only approximate border determination (rating 2), and significant uncertainties in both identification and border assignments (rating 3).

* Reference key (italic entries signify abstracts):

AAC, '85	Andersen, Asanuma, and Cowan, 1985	BP, '89	Barbas and Pandya, 1989
AAES, '90	Andersen, Asanuma, Essick, and Siegel, 1990	BRL, '87	Baylis, Rolls, and Leonard, 1987
B, '05	Brodman, 1905	BUD, '90	Boussaoud, Ungerleider, and Desimone, 1990
B, '85	Brady, 1985	CGOG, '88	Colby, Gattass, Olson, and Gross, 1988
B, '88	Barbas, 1988	CG, '89	Cavada and Goldman-Rakic, 1989a
BAS, '90	Blatt, Andersen, and Stoner, 1990	DU, '86	Desimone and Ungerleider, 1986
BDG, '81	Bruce, Desimone, and Gross, 1981	F, '86	Fenstermaker, 1986
BGBS, '85	Bruce, Goldberg, Bushnell, and Stanton, 1985	FBV, '87	Felleman, Burkhalter, and Van Essen, 1987

tex (including the visual-association areas) occupies an estimated 5385 mm², or 55% of the neocortex. As noted previously, the visual cortex dwarfs the regions devoted to somatosensory, motor, and auditory processing, which occupy 11%, 8%, and 3% of neocortex, respectively. Finally, the remainder of the neocortex consists of areas in the cingulate region on the medial wall (450 mm²), in the prefrontal cortex (930 mm²), and in the insular region between the frontal and temporal lobes. To provide a physical perspective for

these numbers, it is useful to note that the visual cortex as a whole has about the same surface area as a medium-sized cookie (about 8 cm diameter), while the entire cerebral cortex in one hemisphere corresponds to a large cookie (about 12 cm diameter).

Individual visual areas on the cortical map span a 50-fold range in size. V1 and V2 are by far the largest, with each occupying 1100–1200 mm², or 11–12% of the neocortex. V4 is about half their size (540 mm²). Ten areas are in the intermediate range of 100–200

Table 1
Continued

Alternative Name	References ^c	Alternative Scheme	References ^c
area 17			
V-II		area 18	B, '05
V3d	GSG, '88		
V3v	GSG, '88	V4pm/V4al V4/TEO border	MB, '84 GSG, '88
V5	SZ, '85	OAA	SP, '78
TEOd	IY, '88	TEO	F, '86; IY, '87
TEOv	IY, '88	TEO TEd; TEp; TEa/TEm TEv; TEp; TE3/TE2 TEd; TEa; TE1/TE2 TEv; TEa; TE1/TE2 STP; PGa/IPa/TPO 3, 4 STP; IPa/TPO 1.2 TFm, TFI TFI, TF2	F, '86; IY, '87 SP, '78; BRL, '87; IY, '87; YNSI, '88 SP, '78; BRL, '87; IY, '87; YNSI, '88 SP, '78; BRL, '87; IY, '87; YNSI, '88 SP, '78; BRL, '87; IY, '87; YNSI, '88 BDG, '81; SP, '89 BDG, '81; SP, '89 AAES, '90 B, '85
MSTc	BUD, '90	DSR area; DMZ	SYTKFI, '86; UD, '86
MSTp	BUD, '90	part of V3A 7ip; LIPd/LIPv; POa-e/POa-i VIP*; 7ip; POa-i; IPd	VZ, '78 SP, '80, '86; CG, '89; BAS, '90 SP, '80; UD, '86; B, '88; CG, '89
DPL		IPG; PP; PG	V, '85 VB, '47; BUD, '90
Principal sulcus	CG, '89	8a; FDγ 9	W, '40; VB, '47 B, '05
FDV, '85	<i>Felleman, DeYoe, and Van Essen, 1985</i>		SP '89
GGS, '81	<i>Gattass, Gross, and Sandell, 1981</i>		SYTKFI, '86
GSG, '88	<i>Gattass, Sousa, and Gross, 1988</i>		
IY, '87	<i>Iwai and Yukie, 1987</i>		SZ, '85
IY, '88	<i>Iwai and Yukie, 1988</i>		UD, '86
KW, '88	<i>Komatsu and Wurtz, 1988a</i>		V, '85
MA, '86	<i>May and Andersen, 1986</i>		VB, '47
MB, '84	<i>Maguire and Baizer, 1984</i>		VFDOK, '91
MV, '83	<i>Maguire and Van Essen, 1983</i>		
MV, '87	<i>Maunsell and Van Essen, 1987</i>		VMB, '81
NMV, '86	<i>Newsome, Maunsell, and Van Essen, 1986</i>		VNM, '84
SDGM, '89	<i>Stanton, Deng, Goldberg, and McMullen, 1989</i>		VNMB, '86
SP, '76	<i>Seltzer and Pandya, 1976</i>		VZ, '78
SP, '78	<i>Seltzer and Pandya, 1978</i>		W, '40
SP, '80	<i>Seltzer and Pandya, 1980</i>		YNSI, '88
SP '86	<i>Seltzer and Pandya, 1986</i>		Z, '78
			Seltzer and Pandya, 1989b
			Saito, Yukie, Tanaka, Kikosaka, Fukada, and Iwai, 1986
			Shipp and Zeki, 1985
			Ungerleider and Desimone, 1986b
			Van Essen, 1985
			Von Bonin and Bailey, 1947
			Van Essen, Felleman, DeYoe, Olavarria, and Kriernm, 1991
			Van Essen, Maunsell, and Bixby, 1981
			Van Essen, Newsome, and Maunsell, 1984
			Van Essen, Newsome, Maunsell, and Bixby, 1986
			Van Essen and Zeki, 1978
			Walker, 1940
			Yukie and Iwai, 1988
			Zeki, 1978a,b

mm², and 18 areas are small (by macaque standards), ranging from 100 mm² down to a low value of 25 mm² for area MSTl.

There are several sources of uncertainty associated with these estimates of surface area. The cortical map itself (Fig. 2) has some areal distortions, whose magnitude is likely to be in the range of 10%–20% for most regions of the map, but is probably larger in some regions (cf. Van Essen and Maunsell, 1980). There are also inaccuracies in our transposition of

areal boundaries defined in other studies onto the particular hemisphere used for this map (see above). These are hard to quantify, but they probably reflect errors of 50% or more for some areas. Finally, there is intrinsic variability in the size as well as the location of particular areas from one brain to the next. Areas with sharply defined borders such as V1 and MT show roughly 2-fold individual variability in surface area (Van Essen et al., 1981, 1984), and it seems likely that this range will be applicable to most, if not all, cortical

Table 2
Surface area of cortical subdivisions in the macaque

Subdivision	Cortical Area	Area (mm ²)	% of Visual Cortex	% of Neocortex	% of Cerebral Cortex
Visual Areas					
Occipital	V1	1120	20.8	11.5	
	V2	1190	22.1	12.2	
	V3	120	2.2	1.2	
	VP	95	1.8	1.0	
	V3A	110	2.0	1.1	
	V4	540	10.0	5.5	
	VOT	75	1.4	0.8	
	V4t	35	0.6	0.4	
	MT	55	1.0	0.6	
Total Occipital		3340 mm ²	62.0%	34.0%	
Temporal	FST	65	1.2	0.7	
	PITd	200	3.7	2.0	
	PITv	190	3.5	1.9	
	CITd	80	1.5	0.8	
	CITv	120	2.2	1.2	
	AITd	70	1.3	0.7	
	AITv	110	2.0	1.1	
	STPp	120	2.2	1.2	
	STPa	90	1.7	0.9	
	TF	100	1.9	1.0	
	TH	45	0.8	0.5	
	Total Temporal		1190 mm ²	22.0%	12.0%
Parietal	MSTd	35	0.6	0.4	
	MSTl	25	0.5	0.3	
	PO	75	1.4	0.8	
	PIP	85	1.6	0.9	
	LIP	55	1.0	0.6	
	VIP	40	0.7	0.4	
	MIP	55	1.0	0.6	
	MDP	50	0.9	0.5	
	DP	50	0.9	0.5	
	7a	115	2.1	1.2	
Total Parietal		585 mm ²	11.0%	6.0%	
Frontal	FEF	70	1.3	0.7	
	46	200	3.7	2.0	
Total Frontal		270 mm ²	5.0%	3.0%	
Total Visual Cortex		5385 mm ²	100.0%	55.0%	52.0%
Other Neocortex					
Somatosensory		1130		11.5	
Motor		770		7.9	
Auditory		330		3.4	
Gustatory		40		0.5	
Prefrontal (Areas 9, 10, 11, 12, 13, 14, 25, 32, 45)		920		9.4	
Cingulate (Areas 23, 24, 29, 30, PS)		520		5.3	
Perirhinal (35/36)		160		1.6	
Unspecified Neocortex		515		5.3	
Total Neocortex		9970 mm ²		100.0%	94.0%
Transitional Cortex					
Hippocampal Formation					
Subiculum		65			
CA1		70			
CA3		110			
Total Hippocampal Cortex		245 mm ²			2.3%
Transitional Areas					
Presubiculum		15			
Parasubiculum		20			
Entorhinal		160			

Table 2
Continued

Subdivision	Cortical Area	Area (mm ²)	% of Visual Cortex	% of Neocortex	% of Cerebral Cortex
Pro		50			
Pall		25			
Total Transitional Cortex		270 mm ²			2.6%
Paleocortex					
Pyriform		65			
Periamygdaloid		55			
Total Paleocortex		120 mm ²			1.2%
Total Non-neocortex		635 mm ²			6.1%
Total Cerebral Cortex		10575 mm ²			100.0%

This table shows surface area estimates for different cortical areas, geographic regions, and modality-specific regions. Surface areas were calculated from the 2-D cortical map illustrated in Figure 2. Values are shown as absolute surface areas (mm², corrected for tissue shrinkage) and as percent of total visual cortex, total neocortex, and/or total cerebral cortex. Absolute values are shown to 2 significant digits or, for small areas, to the nearest 5 mm². A number of uncertainties apply to all of these estimates (see text), and the values for individual areas should, in general, be regarded as accurate only to within about a factor of 2.

areas. Thus, the values in Table 2 should be regarded as only rough approximations to the physical extent of any given area in any particular hemisphere.

Connectivity

Nearly all of the areas included in this scheme can be distinguished on the basis of their overall pattern of connectivity, and for many, this is the primary basis for identification. This can be seen from Table 3, which gives a concise summary of the corticocortical visual pathways identified as of mid-1990. Each entry in the 2-D matrix denotes the status of a pathway (present, absent, unknown, or questionable) from an area shown on the left to an area shown on the top. Specifically, a plus sign (+) signifies an identified pathway, a dot (·) signifies a pathway that has been tested for and found absent, "NR" (nonreciprocal) signifies a pathway that is reported to be absent in one direction even though the projection in the reverse direction has been demonstrated, and a question mark (?) signifies a pathway that has been reported but is questionable owing to individual variability in occurrence or conflicting reports from different laboratories. For each area, one can quickly ascertain all of its outputs by scanning the appropriate horizontal row and all of its inputs by scanning the appropriate vertical column. In some cases, a pathway has been identified that involves a coarse subdivision (e.g., PIT) but cannot yet be assigned to the finer subdivisions indicated by more recent evidence (e.g., PITd and PITv). Consequently, we have included entries for both coarser and finer subdivisions when appropriate in the table.

Additional information on the characteristics of these pathways is provided in a subsequent section (see Table 5). This will include specific references for every connection and documentation of the questionable or controversial nature of certain connections. Many of the recently identified pathways are reported only in abstracts, and it is important not to give them the same credence as pathways that are illustrated or otherwise well documented in full-length

reports. On the other hand, our description would be out of date if we included only the latter category. The compromise that we have adopted is to use large symbols for pathways in Table 3 that are documented in full-length publications and small symbols for the remainder.

It is apparent that each visual area has many inputs and outputs. Moreover, the particular pattern of connections is distinctive for each area, in terms of the overall constellation of inputs and outputs. In most cases, this pattern provides a characteristic "fingerprint" that can uniquely distinguish one area from all others. This is particularly true for areas whose connections have been thoroughly studied, such as those in the occipital lobe. Many areas, particularly the recently defined ones, have yet to be studied in detail; hence, our description of the connectional pattern is surely far from complete. For example, areas MDP and MIP each have only 2 connections shown in Table 3, but neither of these areas has yet been studied by making direct tracer injections into them.

Our emphasis on connectional information in the identification of areas continues a recent trend away from the traditional primacy given to architectonically defined subdivisions. The justification for this is largely empirical. There are now numerous instances where the original architectonic subdivisions of the classical neuroanatomists conflict with areas defined by connections or topographic organization. In several of these cases, reexamination of cortical architecture has revealed previously unrecognized architectonic transitions that do coincide with the boundaries of visual areas identified on connectional grounds, as in the cases of V3 and MT (Van Essen et al., 1981, 1986) and FST (Boussaoud et al., 1990). It is likely that there will be additional examples of this type, in part because standard Nissl and myelin stains can now be supplemented with histochemical and immunocytochemical markers that reveal distinctive patterns for different areas (cf. Hendry et al., 1988; DeYoe et al., 1990). Also, newly developed procedures for flatten-

Table 3
Matrix of connections in visual cortex

From:	OCCIPITAL										TEMPORAL										PARIETAL										FRONTAL					
	To:										PIT					CIT					STP															
	V1	V2	V3	VP	V3A	V4	VOT	V4t	MT	FST	PITd	PITv	CITd	CITv	AITd	AITv	STPp	STPa	TF	TH	MSTd	MSTl	PO	PIP	LIP	VIP	MIP	MDP	DP	7a	FEF	46				
V1	+	+	+	+	+	+	NR	+													?	+	+													
V2	+	+	+	+	+	+	+	+													+	+	+	+		+						?				
V3	+	+	+		+	+	+	+													+		+	+	+	+						?				
VP		+	+	+	+	+		+	+												+		+	+		+						?				
V3A	+	+	+	+	+			+	+												+	+	+					+				?				
V4	+	+	+	+	+	+		+	+	+	+	+	+	+	+	+	+	+	+	+	+	+	+	+	+	+	+	+	+	+	+	+				
VOT		+		+		+				+	+																									
V4t	+		+					+	+													NR?	+	+								?				
MT	+	+	+	+	+	+		+	+												+	+	?	+	+	+						+	?			
FST		NR?	+	NR?	+	+	+	+	+							+					+	+		+	+					+	+					
PITd						+								+	+	+																				
PITv						+								+	+																					
CITd						+								+	+																					
CITv						+								+	+																					
AITd														+	+																		+	+	+	
AITv						+								+	+							+	+													
STPp									+					+							+	+	+	+	+								+	+		
STPa																																		+		
TF			+	+		+			+					+	+	+	+	+	+	+	+											+	+			
TH						+								+	+	+	+	+	+	+	+												+	+		
MSTd		+	+	+	+			+	+	+	+					+							+	+	+				+	+	+	+	+			
MSTl	NR	+			+			NR?	+	+						+							+		+				NR?	NR?			+			
PO	+							+														+	+		+	+						+	+	?		
PIP	+		+	+	+			+														+												+	+	
LIP			+	+	+	+		+	+												+		+	+	+		+						+	+	+	
VIP			+					+	+													+	+	+	+									+	+	
MIP																							+												+	
MDP																							+												+	
DP					+	+			+														+	+	+	+								+	+	
7a															+							+	+	+	+								+	+	+	
FEF									?	+				+	+	+						+	+	+	+	+	+	+	+	+	+	+	+	+	+	
46														+	+	+	+	+	+	+	+													+	+	+

This table is a connectivity matrix for interconnections between visual cortical areas in the macaque. Each row shows whether the area listed on the left sends outputs to the areas listed along the top. Conversely, each column shows whether the area listed on the top receives inputs from the areas listed along the left. Large plus symbols (+) indicate a pathway that has been reported in 1 or more full-length manuscripts; small plus symbols indicate pathways identified only in abstracts or unpublished studies. Specific citations are listed in Table 5. Dots (-) indicate pathways explicitly tested and found to be absent. Blanks indicate pathways not carefully tested for. Question marks (?) denote pathways whose existence is uncertain owing to conflicting reports in the literature. "NR" and "NR?" indicate nonreciprocal pathways, i.e., connections absent in the indicated direction even though the reciprocal connection has been reported. Shaded boxes along the diagonal represent intrinsic circuitry that exists within each area; these are not included among the pathways tabulated in the following table.

ing the cortex prior to sectioning can facilitate the recognition of subtle architectonic transitions (Olavarria and Van Sluyters, 1985; Tootell and Silverman, 1985).

Specific Visual Areas

In order to put the current map into perspective, it is useful to comment on the layout of specific visual areas, with emphasis on recently identified areas and areas for which uncertainties in identification persist.

We will begin with the 9 areas of the occipital lobe. First, there is a triplet of large, well-studied areas, V1, V2, and V4, each of which contains a complete topographic representation. These are surrounded anteriorly by a collection of smaller areas, 3 of which have been mapped in some detail (MT, V3, and VP), and the remainder of which are less well characterized (V3A, V4t, and VOT). V3A was originally identified and mapped by Van Essen and Zeki (1978), but its borders have been revised (see area PIP below).

Desimone and Ungerleider (1986) identified area V4t (transitional V4) as a narrow strip between MT and the dorsal half of V4; it can be distinguished from both of these neighbors by its architecture, connectivity, and neuronal receptive field properties (cf. also Schein et al., 1982; Perkel et al., 1986; Gattass et al., 1988). In ventral occipital cortex, we have identified area VOT (the ventral occipitotemporal area) as a narrow cortical strip sandwiched between the ventral half of V4 and the inferotemporal cortex (Felleman et al., 1985; Van Essen et al., 1991). VOT lies just posterior to a callosal-recipient strip that delineates the border of inferotemporal cortex (Van Essen et al., 1982). V4t and VOT contain representations of the lower and upper parts of the visual field, respectively; we provisionally consider them to be separate areas with incomplete visual representations, much as has been argued for areas V3 and VP (Burkhalter et al., 1986).

In the parietal lobe, the visual cortex occupies most or all of Brodmann's area 7 (PG and PE of von Bonin and Bailey, 1947). This region includes 3 areas (PO, PIP, and DP) situated posteriorly, 5 areas (7a, LIP, VIP, MIP, and MDP) situated more anteriorly and arranged in a lateral-to-medial swath that adjoins the somatosensory cortex, and 2 areas (MSTd and MSTl) within the dorsal part of the superior temporal sulcus (STS). MST was originally identified as the region receiving direct inputs from MT and lying near the fundus of the STS (Maunsell and Van Essen, 1983). As initially defined, however, MST is not a homogeneous region. There is now evidence for splitting it into 3 distinct areas: a dorsal region (MSTd), a "lateral" region (MSTl) that is situated ventro-antero-lateral to MSTd, and a region situated even further ventro-antero-laterally in the floor of the superior temporal sulcus (FST), which lies within the temporal lobe but which we consider here because of its affinity with the MST complex. This partitioning is based on findings of (1) different receptive field properties in all 3 regions (Desimone and Ungerleider, 1986; Hikosaka et al., 1988; Komatsu and Wurtz, 1988a,b; Newsome et al., 1988), (2) different connections of all 3 areas (Ungerleider and Desimone, 1986b; Andersen et al., 1990; Boussaoud et al., 1990), and (3) differential effects on pursuit eye movements from selective stimulation of MSTd versus MSTl (Komatsu and Wurtz, 1989).

Area PIP (posterior intraparietal) lies in a region once considered to be part of V3A (Van Essen and Zeki, 1978), but the 2 areas can now be distinguished by their topographic organization and by their connections with other visual areas (Felleman et al., 1987; Colby et al., 1988). Area PO (parieto-occipital) is a topographically organized area situated medial and dorsal to PIP (Colby et al., 1988). Areas MIP (medial intraparietal) and MDP (medial dorsal parietal) have been identified on the basis of their connections with area PO (Colby et al., 1988). Area DP, which occupies the dorsal aspect of the prelunate gyrus, is a major source of visual inputs to area 7a (Andersen et al., 1990). DP has been distinguished from adjoining ar-

ea (V4, V3A, and 7a) primarily on the basis of differential connections, but also on the basis of visual topography and receptive field size and responsiveness (Maguire and Baizer, 1984; May and Andersen, 1986; Andersen et al., 1990). Area 7a, as described by Andersen et al. (1985), occupies the posterior part of the inferior parietal lobule and extends only a short distance into the intraparietal sulcus. Area VIP (ventral intraparietal) occupies the fundus of the intraparietal sulcus (Maunsell and Van Essen, 1983). LIP (lateral intraparietal) lies in the lateral bank of the intraparietal sulcus, in between VIP and area 7a (Andersen et al., 1985). However, there is considerable uncertainty about the border between these areas. On the basis of projection patterns from MT, Maunsell and Van Essen (1983) suggested that VIP was restricted to the fundus of the intraparietal sulcus. Ungerleider and Desimone (1986b) found that MT projections sometimes extend substantially farther up the lateral bank of the sulcus into a heavily myelinated zone that they termed VIP*. This region lies within area LIP as described by Andersen et al. (1985) and may correspond to area LIPv of Blatt et al. (1990) and to the posterior portion of area POa-i of Seltzer and Pandya (1980). Overall, it remains unclear whether this heavily myelinated strip should be considered part of VIP or LIP or as a distinct area unto itself.

The numerous visually related areas of the temporal lobe can be subdivided into 3 broad groups (not counting area FST, which has already been discussed with the parietal areas). The first group lies within the classical inferotemporal cortex (IT), which extends from the lower (posterior) bank of the STS to the lateral bank of the occipitotemporal sulcus. The second group lies within the polysensory strip occupying the upper (anterior) bank of the STS. The third group lies more medially, including the parahippocampal gyrus, and has traditionally been regarded as part of the limbic cortex.

In the present scheme, IT has been subdivided into 6 distinct areas. These can be grouped into 3 pairs, each containing separate dorsal and ventral subdivisions (Felleman et al., 1986; Van Essen et al., 1991; cf. also Fenstemaker et al., 1984; Fenstemaker, 1986). In particular, we distinguish among dorsal and ventral subdivisions of posterior inferotemporal cortex (PITd and PITv), central inferotemporal cortex (CITd and CITv), and anterior inferotemporal cortex (AITd and AITv). The dorsal areas lie largely within the lower bank of the STS, extending a short distance onto the middle temporal gyrus. The ventral areas occupy most of the middle and inferior temporal gyri and extend into the lateral bank of the occipitotemporal sulcus. The distinction between posterior and central pairs is based on topographic organization (present to a crude degree in PITd and PITv but not CITd and CITv) and on the laminar organization of projections back to V4 (Van Essen et al., 1991). Anterior inferotemporal cortex (AIT) differs from CIT in having much weaker connections with V4. The distinction between dorsal and ventral subdivisions (PITd vs. PITv and CITd vs. CITv) is based, in part, on the large sepa-

ration of foci resulting from single V4 injections. In addition, the dorsal subdivisions are reported to have strong connections with nuclei in the amygdalar complex, whereas the ventral subdivisions are more strongly connected with the subicular/hippocampal complex (Fenstemaker, 1986; Iwai et al., 1987; Yukie et al., 1988; but see Suzuki and Amaral, 1990). However, a potential qualification to this latter distinction is that the border between dorsal and ventral subdivisions suggested by Iwai et al. (1987) is more ventral than that illustrated in Figure 2, theirs being approximately in line with the anterior middle temporal sulcus.

Several previous studies have subdivided IT mainly along the anteroposterior axis (Turner et al., 1980; Iwai, 1981; Iwai and Yukie, 1987), the dorsoventral axis (Brodmann, 1905; Horel et al., 1987; Iwai et al., 1987; Yukie et al., 1988), or a mixture of both (Seltzer and Pandya, 1978). Our scheme is, in effect, a combination of the Iwai and Yukie (1987) anteroposterior partitioning with their subsequent dorsoventral partitioning (Yukie et al., 1988).

Immediately dorsal to IT is a long strip of polysensory cortex on the dorsal (anterior) bank of the STS. This strip was identified as the superior temporal polysensory area (STP) by Bruce et al. (1981), because they encountered many auditory and somatosensory responses along with a high incidence of visual responsiveness. Based on connectional differences described in several studies (Seltzer and Pandya, 1989a,b; Boussaoud et al., 1990), we have drawn a distinction between a posterior region, STPp, and an anterior region, STPa. Although it is based to a substantial degree on their connectional data, our scheme differs from that of Seltzer and Pandya (1978). They partitioned this region into 3 longitudinal strips, areas TPO, PGa, and IPa. More recently (Seltzer and Pandya, 1989b), they further subdivided the widest of these strips, area TPO, into 4 subregions along the anteroposterior dimension (TPO1–4). We have refrained from using their finer-grained scheme pending clarification of how robust and consistent the connectional differences are between different subregions.

In the parahippocampal gyrus, areas TF and TH are associated with vision by virtue of their connections with more than a half dozen different visual areas. Both of these areas are also strongly connected with the entorhinal cortex, area 36, and the cingulate cortex (Van Hoesen and Pandya, 1975; Brady, 1985; Insausti et al., 1987), but they apparently lack strong connections with the somatosensory cortex (Friedman et al., 1986; Cavada and Goldman-Rakic, 1989a; Andersen et al., 1990).

Finally, in the frontal cortex, 2 regions have been implicated in visual, visuomotor, or visually guided memory functions. FEF (the frontal eye field) is an area that plays an important role in saccadic eye movements and has extensive connections with visual areas in the occipital and parietal lobes (Bruce and Goldberg, 1984; Bruce et al., 1985). It overlaps partially with architectonic area 8a of Walker (1940), but the 2 are not coextensive (Stanton et al., 1989). Imme-

diately anterior to FEF is area 46 (Walker, 1940; Barbas and Pandya, 1989), which fills most of the principal sulcus and extends onto its dorsal and ventral lips. Based on the heterogeneous pattern of connectivity with parietal and temporal areas, there are probably distinct subdivisions within area 46 (Goldman-Rakic, 1988; Barbas and Pandya, 1989; Cavada and Goldman-Rakic, 1989b; Seltzer and Pandya, 1989a), but a coherent scheme for subdividing it has yet to emerge.

The collection of visual areas just described is by no means a closed system. There are additional linkages to cortical areas associated with motor function, higher cognitive functions, and other sensory modalities. For example, some visual areas have strong connections with the entorhinal complex, a group of areas that serve as a major gateway to and from the hippocampal formation. There are also pathways that link the visual cortex to the cingulate cortex and to various subdivisions of the prefrontal cortex. Some of these will be discussed later in relation to the notion of hierarchical processing and information flow. Finally, all visual areas also have extensive connections with multiple subcortical nuclei, which will be discussed below.

Reciprocity and Distributed Connectivity

Up to this point, we have used the information in Table 3 to distinguish different areas on the basis of their specific connections. This tabulation also provides a useful framework for discussing other important principles concerning the numbers and patterns of connections among different areas.

The first principle is that of reciprocity of corticocortical connections. More than a decade ago, it was noted that pathways within the visual cortex tend to be bidirectional, such that if area *A* projects to area *B*, then area *B* is likely to project in turn to area *A* (Tigges et al., 1973; Rockland and Pandya, 1979). The degree to which this relationship holds is reflected in the symmetry of Table 3 about the diagonal axis (shaded boxes). If connections were invariably reciprocal, each entry would have a counterpart at the mirror-symmetric position on the opposite side of the diagonal.

Altogether, there are 305 identified pathways entered in Table 3, including 53 pathways reported only in abstracts and 13 pathways explicitly listed as questionable on the basis of conflicting reports (cf. Table 5). The majority of these pathways (242) are demonstrably bidirectional, forming 121 pairs of reciprocally interconnected areas (Table 4). Of the remaining "singlet" pathways, nearly all (58 of 63) are cases in which there has not been a clear-cut test for the reverse direction. However, there are a few examples of apparently unidirectional corticocortical pathways. In particular, there is a reported lack of reciprocity in the projections from V4t to V1 (Perkel et al., 1986; Ungerleider and Desimone, 1986b; Van Essen et al., 1986), from V2 to FST, and from V4t and DP to MSTl (Boussaoud et al., 1990). An intermediate example is the linkage between V1 and V4, which reportedly is robust and consistent from V4 to V1 (Perkel et al.,

1986), but relatively weak and occasional from V1 to V4 (Van Essen et al., 1986), in a way that may depend on eccentricity (Zeki, 1978a, 1980). Thus, the reciprocity of connections may, in some cases, vary among individuals or from one location to another within an area. However, in evaluating such possibilities, it is important to bear in mind that different tracer substances and different injection protocols can vary enormously in their sensitivity and thus in their ability to reveal relatively weak or diffuse projections. Pathways that appear absent or sparse using one pathway-tracing approach (e.g., from V1 to PO; Van Essen et al., 1986) may appear much more robust when using larger injections of a more sensitive tracer (Colby et al., 1988). For this reason, we have avoided attempting to systematically report the magnitude or density of these connections, even though such information would be extremely useful to have.

Table 4 provides several additional types of information about the overall population statistics for the connections between cortical areas. In particular, it is possible to estimate the average number of corticocortical connections made by each visual area, the range among different areas, and what fraction of the total number of possible connections are actually made. Analyses of this type become increasingly meaningful now that the number of identified pathways has outstripped the ability and/or desire of most investigators to keep track of them all individually. There are several ways of evaluating the data, however, owing to the fact that the charting of visual pathways is still far from complete. A lower bound on the overall degree of connectivity can be set from the overall number of 305 identified pathways linking 32 visually related neocortical areas. Because each pathway is an input to one area and an output from another, this works out to an average of about 19 connections per area (nearly 10 inputs and 10 outputs per area). A better estimate can be obtained by considering only those areas that have been extensively studied using both anterograde and retrograde tracer injections. For the 5 best-studied areas, V1, V2, V3, V4, and MT, the average number of connections per area is 27. The average number of areas with which there is any linkage (i.e., a connection in at least 1 direction) is 15 for this group. Interestingly, there is more than 2-fold variability in connectivity even among these well-studied areas. At the low end, V1 has "only" 16 connections that link it to 9 areas (3 robust, reciprocal pairs plus various minor, occasional, or unidirectional pathways). At the high end, V4 has 39 identified connections with 21 areas, signifying that it is linked to about $\frac{3}{4}$ of all known visual areas. Moreover, the majority of these are robust pathways, suggesting that V4 may play a pivotal role in many different aspects of cortical processing.

In a fully interconnected network involving N areas, there would be a total of $N(N - 1)$ connections. For $N = 32$ areas, this number would be 992 pathways (446 pairs). By expressing the 305 reported pathways as a fraction of this theoretical limit, we conclude that nearly $\frac{1}{2}$ of all possible connections have been em-

Table 4
Connectivity patterns among visual areas

Reciprocity	
Total number of pathways	305
Reciprocal pathways	121
Singlet pathways	63
Critically tested	5
Not critically tested	58
Connectivity	
Total number of pathways	305
Total number of areas	32
Average number of pathways per area	19
Highest number of pathways per area	39
Average number of pathways per well-studied area	27
Average number of linkages per well-studied area	15
Maximum possible connectivity among 32 areas	992
Observed pathways	$305/992 = 31\%$

pirically demonstrated. If each area has an average of 27 connections, as found for well-studied areas, the connectivity level would exceed 40% of the theoretical limit (432/992). If we take into account the fact that only about 680 of the 992 possible pathways have been explicitly tested, the 305 identified pathways represent a connectivity level of approximately 45%. Finally, if we assume that each area is connected with 15 other areas on average and that nearly all of these linkages will turn out to be reciprocal, then the estimated connectivity level approaches 50%. Of course, some of the pathways whose existence is reported to be questionable or only occasional in occurrence may, upon more careful scrutiny, turn out to be absent altogether, but we doubt that this will occur very frequently. Thus, no matter how the estimates are generated, there is no escaping the notion that the visual cortex is a highly distributed information-processing system. To keep this conclusion in perspective, however, we reemphasize that different pathways vary enormously in strength. Quantitative data on this issue are scarce, but we estimate that there may be a range of 2 orders of magnitude or more in the percentages of cells that project from a given target area. The fraction of pathways that are "robust," in the sense of showing heavy labeling when analyzed with conventional tracers, may be only 30%–50% of the total number of identified connections.

Hierarchical Relationships in the Visual Cortex

The possibility that the visual cortex might operate by a strictly serial processing scheme can be ruled out just from knowing the multiplicity of connections per area and the near ubiquity of reciprocal connections. On the other hand, it seems highly unlikely that the visual cortex is a network that altogether lacks any distinction between processing levels. Many studies, both electrophysiological and lesion based, indicate that some visual areas, such as those in the temporal and parietal lobes, are involved in a higher level of information processing than that mediated by occipital areas such as V1 and V2 (cf. Ungerleider and Mishkin, 1982; Van Essen, 1985; Maunsell and New-

some, 1987; Goldman-Rakic, 1988). Between these 2 extremes (a strictly serial scheme on the one hand and a completely nonordered network on the other), there are many intermediate possibilities. One hypothesis is that cortical areas are hierarchically organized in some very well-defined sense, with each area occupying a specific position in relationship to all other areas, but with more than 1 area allowed to occupy a given hierarchical level. Another possibility is that a hierarchy exists only in a loose sense, for instance, at the level of the different cerebral lobes, but not in any precisely definable manner for individual cortical areas.

To illustrate the importance of such distinctions, consider for a moment an analogy with various groupings characteristic of human societies, including social, political, and business organizations (e.g., the U.S. government). Except in a complete anarchy, there is generally some form of hierarchical organization, in which there are leaders and followers, chairpersons and committee members, or various other measures of rank. Some organizations have an utterly rigid hierarchy, in which every individual knows precisely his or her place within a pecking order. Others are less well defined, and there may be basic uncertainties as to who ranks above whom in various interactions. Still others may be inherently fluid and context dependent, in that one person ranks above another in one particular circumstance but below the other in another circumstance (e.g., on different committees). Distinguishing among such possibilities can be pivotal for understanding the operation of any complex system, whether it be in the domain of the cerebral cortex or of human society. It is worth noting in general terms that information flow in a hierarchical system (1) can go in both directions (upwards and downwards), (2) can skip over intermediate levels to go directly from a low to a high level, and (3) can travel in parallel through multiple, functionally distinct channels.

Current ideas about hierarchical organization in the primate visual system were spurred by notions of forward and feedback pathways suggested by connectivity patterns. In particular, Rockland and Pandya (1979) noted that projections in one direction tend to originate from superficial layers and terminate in layer 4, whereas those directed in the opposite direction tend to arise from deep as well as superficial layers and to terminate outside layer 4. They suggested that these 2 directions might correspond to forward and feedback directions of information flow. Subsequently, this notion was used as a basis for proposing an explicit, anatomically based hierarchy of visual cortical areas (Maunsell and Van Essen, 1983). In addition to ascending (forward) and descending (feedback) pathways, a few pathways were hypothesized to represent lateral information flow between areas at the same level. This designation was assigned to pathways terminating in a columnar pattern, involving all cellular layers to a comparable extent. The original version of the cortical hierarchy in the macaque visual pathway spanned 6 levels and was based

on 36 distinct pathways among 13 identified cortical areas. Subsequently, this was extended to 7 hierarchical levels, based on 92 pathways among 17 cortical areas (Van Essen, 1985).

The number of identified pathways for which useful laminar information is available has more than tripled in the past 5 years. Given this huge increase in recently available information, our aim here is to assess whether the same or similar principles of organization allow for the incorporation of many more cortical areas and pathways into a single, internally consistent hierarchy. Our analysis indicates that the hierarchy can indeed be expanded to include all of the visually related areas for which connective data exist. However, this has entailed a significant modification in the criteria used for distinguishing forward and feedback pathways. There are also a number of apparent inconsistencies. Some of these may represent bona fide exceptions to the general rule, but we suspect that the majority reflect inaccurate assignments stemming from technical considerations that will be discussed below.

Criteria

Our revised criteria for identifying hierarchical relationships are illustrated schematically in Figure 3. This scheme is similar to previously published ones (Van Essen and Maunsell, 1983, their Fig. 2; Maunsell and Van Essen, 1983, their Figs. 6, 13), but it has been expanded to include all major types of laminar patterns identified to date. The different patterns are arranged to show the laminar distributions of cells of origin and axonal terminations that we consider to be indicative of ascending (A, upper row), lateral (L, central row), and descending (D, bottom row) pathways.

For the axonal terminations of any given pathway, we distinguish 3 characteristic patterns as revealed by anterograde tracer injections (Fig. 3, center column). In one pattern (F), terminations are densest in layer 4, though they may also be prominent in layer 3 and other layers, as well. In another pattern (M), terminations preferentially avoid layer 4, usually forming a multitier pattern including both superficial and deep layers. Occasionally, patterns are encountered that involve primarily superficial layers (e.g., layers 1 and 2 in the projection from V4 to V1; predominantly layer 3 in the projection from AITd to FEF). Even though these are not strictly multilaminar, we have grouped them in the same category because they appear to represent descending pathways. In the third pattern (C), terminations extend in a columnar fashion continuously and with relatively uniform density across layer 4, often extending the entire thickness of the cortex.

For the cells of origin of each pathway, we distinguish 3 characteristic patterns as revealed by retrograde labeling experiments (Fig. 3, left and right columns). In one pattern (S), a large majority of cells (>70%) lie in supragranular layers. In another pattern (I), a large majority (>70%) lie in infragranular layers. In the third pattern (B), there is a strongly mixed

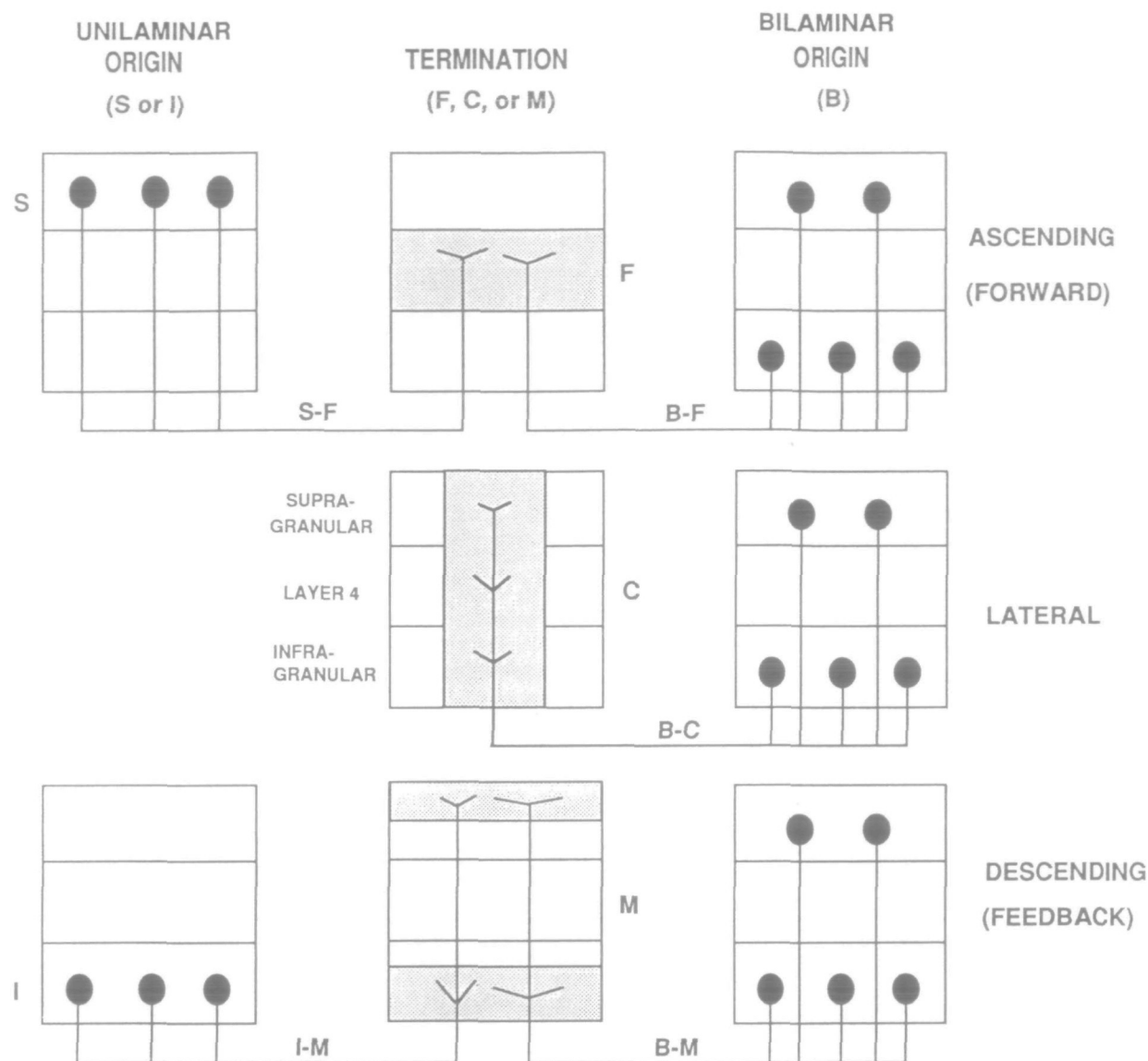

Figure 3. Laminar patterns of cortical connectivity used for making hierarchical assignments. Three characteristic patterns of termination are indicated in the *central column*. These include preferential termination in layer 4 (the *F* pattern), columnar (*C*) pattern involving approximately equal density of termination in all layers, and a multilaminar (*M*) pattern that preferentially avoids layer 4. There are also 3 characteristic patterns for the cells of origin of different pathways. Bilaminar (*B*) patterns, shown on the *right*, include approximately equal numbers of cells from superficial and deep layers (no more than a 70%–30% split) and are found to occur with all 3 types of termination pattern. Unilaminar patterns include predominantly superficial-layer inputs (*S* pattern), which correlate with *F*-type terminations, and predominantly infra-granular-layer inputs (*I* pattern), which correlate with *M*-type terminations. Within this general framework, a number of variations on a theme can be encountered. Some pathways terminate primarily in superficial layers, but we group them with the *M* pattern because they avoid layer 4. Other pathways are quasi columnar, but do not include all layers; we classify them as a *C* pattern if the labeling in layer 4 is neither heavier nor sparser than in adjoining layers.

(bilaminar) distribution, with roughly similar proportions (30%–70%) of the labeled cells in each compartment.

Ascending projections were originally proposed always to originate predominantly from superficial layers (*S* pattern; Rockland and Pandya, 1979; Maunsell and Van Essen, 1983). However, a few pathways, such as that from DP to 7a (Andersen et al., 1990), are now known to originate in a bilaminar (*B*) pattern and yet terminate mainly in layer 4 (*F* pattern). Such *B*–*F* combinations invalidate one of the initial assumptions about feedforward pathways, but they do not necessarily invalidate the notion of hierarchical organization. The key issue is whether a consistent

hierarchical scheme can be identified using a modified set of criteria. The modification that we propose is to treat any bilaminar retrograde pattern as ambiguous if it is the only type of laminar information available. Conversely, it is compatible with any of the 3 hierarchical relationships (*A*, *L*, or *D*) that may be indicated from other data on a given pathway. A similar suggestion has been made by Andersen et al. (1990) and Boussaoud et al. (1990).

A Database for Analyzing Hierarchical Relationships

Our goal in this section is to apply the scheme illustrated in Figure 3 as objectively and rigorously as

possible to the analysis of hierarchical relationships in the visual cortex, while taking into account the uncertainties and qualifications that are associated with some of the experimental data. In principle, the task is no different than for the hierarchical schemes that we and others have proposed previously. However, in practice, we found the analysis to be much more difficult, owing to the sheer amount and complexity of anatomical data now available. It became essential to establish a computerized database in order to handle the data efficiently and examine all relationships critically. We used the EXCEL database package, which runs on both Macintosh and PC-compatible computers.

The format we used for the database is illustrated in Table 5. The first 12 columns on the left provide information about the laminar patterns of connections and the hierarchical relationships that can be inferred from them. The 6 columns on the right provide specific citations, listed separately for the origins and terminations of each pathway.

Each row across the table deals with both pairs of a reciprocal linkage (e.g., from V1 to V2 in columns 1–5 and from V2 back to V1 in columns 6–10). The connections of V1 are listed first, because its outputs (left) are all of the ascending type and its inputs (right) are all descending. Those of V2 are listed next, because its outputs are all ascending, except for the linkage with V1 that has already been accounted for. The sequence continues by selecting areas in an order (V3, VP, etc.) chosen so that the output pathways remaining to be listed (columns 1–5) are all ascending, lateral, or indeterminate, the descending pathways having already been listed.

The complete hierarchical analysis involved 4 major stages, and it is useful to outline the overall sequence briefly before discussing each stage in detail. For each pathway under consideration, the first step is to use the available laminar information to make assignments according to the categories we have proposed for retrograde labeling (S, B, or I designations in columns 3 and 8) and anterograde labeling (F, C, or M designations in columns 4 and 9). One or 2 key references for each of these assignments are listed in the appropriate column (13, 14, 16, or 17) on the right. For pathways that have been identified in several studies, we have selected those references that provide the best information on laminar patterns, rather than necessarily the first study or the most recent study. As in Table 1, the references are designated by abbreviations that are matched to the standard citation format in the table notes. With a little experience, one can quickly recognize the specific study associated with any given finding contained in the table. In order to facilitate making distinctions between pathways that are identified on the basis of abstract versus those documented by full reports, all of the abstracts in the reference key are italicized.

The second step in the analysis is to make assignments of the direction of information flow (ascending, lateral, or descending) based on the laminar information available for each pathway. Using the criteria

illustrated in Figure 3, the entries in column 3 and 4 are used to make the assignments of A, L, or D shown in column 5, while the entries in columns 8 and 9 are used for the assignments shown in column 10. Columns 5 and 10 also contain many “u” entries, which stand for a pathway whose existence is documented but whose hierarchical assignment is undefined, either because there is no laminar information whatsoever or because the only information is the nonspecific B (bilaminar) cell-of-origin pattern. The third step is to examine all reciprocal pairs, in order to see whether there is complementarity of the 2 patterns indicated in columns 5 and 10. If one pathway is ascending, the reciprocal path should be descending (an A–D pair), and if one is lateral, its counterpart should also be lateral (an L–L pair). The results are indicated in column 11. The fourth and final step is to determine whether an internally consistent global hierarchy can be assembled by using the relationships inferred from the entire collection of pairwise comparisons. Before we reached this step, there were numerous complexities and subtleties that required careful attention and merit explicit discussion.

Table 5 also contains additional information pertaining to the existence, special nature, or controversial nature of certain pathways, which is indicated in columns 15 and 18 for the 2 directions. Each of these “special” references is preceded by an “E” if the existence of the pathway has been demonstrated but there is no laminar information for either the origin or termination, by an “S” if the pathway is notably sparse, by an “R” if it occurs only rarely, and by an “A” if the pathway has been reported to be altogether absent. However, for simplicity, we filled in this last entry (absent pathways) only for cases of particular interest, for example, when other studies have reported the presence of that pathway or of the pathway in the reciprocal direction. There are a total of 38 entries in the sparse, rare, or absent groups, amounting to slightly more than 10% of the total number of pathways.

The most critical stage of the entire analysis was the entry and validation of experimental data on laminar patterns (Table 5, columns 3, 4, 8, and 9). This is based on information from a total of 52 studies, listed in the table notes. For many studies, the relevant information was already available in an appropriate format, and data entry was straightforward. However, in numerous cases, it was difficult to decide on the appropriate assignment, for reasons that can be grouped into 2 broad categories: (1) *Areal uncertainties*: Many pathways have been reported using a different partitioning scheme than ours for identification of areas (cf. Table 1), and others have been demonstrated by illustrating the connections as they relate to geographical landmarks, without explicit assignment of both tracer injection sites and target sites to specific areas. The ease and reliability with which such data could be related to our partitioning scheme varied widely and depended to a large extent on how much detailed information was given about the pathways under consideration. To facilitate this process,

we often made recourse to comparisons with a scale model of the macaque brain, which was available in our laboratory and was painted according to the scheme illustrated in Figure 3. (2) *Laminar uncertainties*: As with the areal assignments, the determination of laminar patterns associated with each pathway was often difficult, depending on the nature and extent of published information available. Obviously, the easiest cases were those in which the laminar patterns had been analyzed and tabulated using criteria similar to or identical to ours (e.g., Andersen et al., 1990; Boussaoud et al., 1990). However, in many publications, the critical patterns are often illustrated or described only in sketchy or fragmentary fashion.

Altogether, we made numerous judgment calls, many of which are explicitly indicated by question marks (e.g., S?) or mixed assignments (e.g., C/M?) in the relevant columns of Table 5. Because this was an interactive process, frequently requiring discussion and reassessment of the data, it was important to be able to access the published information quickly and repeatedly. For this reason, our computerized database included, in addition to the relevant publications, a listing of their specific page numbers and figure numbers that are particularly informative about laminar patterns. This information is not included in Table 5, simply for reasons of clarity and space.

Step 1: Individual Laminar Patterns

Columns 3 and 8 of Table 5 contain data on cells of origin for 217 pathways, 177 of which fell clearly in the S, B, or I categories illustrated in Figure 3. The 40 irregularities (25 S/B, 14 I/B, and 1 S? patterns) are of several types: (1) borderline patterns (e.g., results showing labeling of roughly $\frac{1}{2}$ infragranular and $\frac{3}{4}$ supragranular neurons but without sufficient quantitation to decide unambiguously between S vs. B patterns), (2) heterogeneous results within a single hemisphere (e.g., some S clusters and some B clusters from a single injection), (3) heterogeneity across different hemispheres used in the same study, and (4) discrepant outcomes reported by different studies. Overall, it is difficult to ascertain how many of these instances represent genuine biological variability within a well-defined pathway and how many represent technical complications and uncertainties. With respect to determining hierarchical relationships, however, the presence of a mixed result (S/B or I/B) in a single pathway does not represent an inherent conflict, because a bilaminar pattern is consistent with all possibilities, ascending, descending, or lateral. Such a conflict would arise if a mixed S/I pattern were encountered for a particular pathway, but we are not aware of any examples of this type. In cases where there is a mixed pattern of origin (S/B or I/B) and no data on termination patterns, a question mark (A? or D?) is used to indicate uncertainty about the hierarchical assignment.

With regard to patterns of termination, columns 4 and 9 of Table 5 contain data on 156 pathways, 132 of which fit cleanly into the F, C, or M categories of Figure 3. The 24 exceptions are listed individually in

Table 6 because, unlike the various irregularities in patterns of cell origin, they represent a potentially serious challenge to our simple scheme for hierarchical relationships. For example, a genuinely mixed F/C pathway would suggest that one area is simultaneously level with and higher than another area. This would be logically inconsistent with a static hierarchy based on our particular anatomical criteria. Although it is obviously critical to know whether these mixed patterns are genuine or artifactual, in most cases, there is insufficient information to resolve the issue unambiguously. Perhaps the clearest example of laminar heterogeneity is the projection from MT to V4, which has been shown in 2 studies to include some patches having a columnar pattern and other patches having a multilayer pattern (Maunsell and Van Essen, 1983; Ungerleider and Desimone, 1986b). It is unlikely that this heterogeneity is an artifact resulting from mistaken assignments of the borders of V4 or MT. Interestingly, however, there is independent evidence for a form of compartmental organization within V4, based on its pattern of connectivity with different subregions of V2 (DeYoe et al., 1988; Zeki and Shipp, 1989; Van Essen et al., 1991). It is unclear whether these 2 types of heterogeneity bear any systematic relationship to one another. Other examples of mixed, or variable, laminar patterns (MST to PO; MSTd and MSTl to FST; LIP to PO and MSTd) represent situations in which both the target area and the injected area are small and lack sharply defined borders. Hence, it is possible that the heterogeneity sometimes resulted from imperfect border assignments in which the injection site or the target region might inadvertently have included 2 areas at different hierarchical levels.

In some instances, the descriptions involve relatively sparse connections in which it is difficult to discern laminar patterns precisely (e.g., DP to PO; Andersen et al., 1990). In other cases, the reported distribution is borderline or intermediate between a clear-cut F or C pattern. For example, the projection from MT to V3A is a borderline pattern in which the text describes a columnar (C) pattern (Ungerleider and Desimone, 1986b), but in the accompanying illustration (their Fig. 2), the labeling appears slightly denser in superficial and deep layers than in layer 4 and hence could arguably correspond to a multilayer (M) pattern (see Seltzer and Pandya, 1989a, for other examples of this type).

Interestingly, there are only 2 cases of F/M termination patterns, that is, involving a direct conflict between ascending and descending directions. In one case (area 7a to STP; Andersen et al., 1990), there is independent evidence that the target region includes 2 separate areas (STPp and STPa) at different hierarchical levels, but the projections are not described in sufficient detail to ascertain whether the F pattern is in STPa and the M pattern in STPp, as we would predict. In the other case (FST to FEF; Boussaoud et al., 1990), the projection was to 2 separate foci in the arcuate sulcus having different termination patterns, but it is unclear whether both foci were within the

Table 5
Connectivity table for visual areas

1	2	3	4	5	6	7	8	9	10	11	12
Outputs					Inputs					Hierarchical relationship	Levels crossed
From	To	Origin (S, B, I)	Termination (F, C, M)	Direction (A, L, D)	From	To	Origin (S, B, I)	Termination (F, C, M)	Direction (A, L, D)		
V1	V2	S	F	A	V2	V1	B	M	D		
	V3	S	F	A	V3		B	M	D	A-D	2
	V3A		F	A	V3A		I		D	A-D	3
	PIP		F	A	PIP				u		3
	V4	S		A	V4		B	M(s)	D?	A-D?	4
	V4t				V4t		I		D	NR	4
	MT	S	F	A	MT		I	M	D	A-D	4
PO	S		A	PO				u		4	
MSTl	S		A	MSTl						NR	6
V2	V3	S	F	A	V3	V2		M	D	A-D	1
	VP	S	F	A	VP		B	M	D	A-D	1
	V3A	S	F	A	V3A			M	D	A-D	2
	PIP			u	PIP						2
	V4	S	F	A	V4		B	M	D	A-D	3
	VOT			u	VOT				u		4
	V4t	S	F	A	V4t						3
	MT	S	F	A	MT		B	M	D	A-D	3
	PO	S		A	PO						3
	MSTd	S	F	A	MSTd			M	D	A-D	5
	MSTl	S		A	MSTl			M	D	A-D	5
	FST	S		A?	FST					NR?	5
	VIP			u	VIP						5
FEF	S		A	FEF						6	
V3	VP				VP	V3	B		u		0
	V3A		F	A	V3A		I	M	D	A-D	1
	PIP		F	A	PIP		B		u		1
	V4	S	F	A	V4		I	M	D	A-D	2
	V4t	S	F	A	V4t		B		u		2
	MT	S	F	A	MT		B	M	D	A-D	2
	PO	S		A	PO						2
	MSTd	S	F	A	MSTd		I		D	A-D	4
	FST	S		A	FST			M	D	A-D	4
	LIP		F	A	LIP		I		D	A-D	4
	VIP		F	A	VIP		I		D	A-D	4
	FEF	S		A	FEF						5
	TF		F	A	TF		I		D	A-D	7
VP	V3A		F/C	A/L?	V3A	VP	B		u		1
	PIP		F	A	PIP		B		u		1
	V4	B	F	A	V4		I		D	A-D	2
	VOT		F	A	VOT			M	D	A-D	3
	MT	S	F	A	MT		I	M	D	A-D	2
	PO	S		A	PO						2
	MSTd	S	F	A	MSTd		I		D	A-D	4
	FST	S	F	A	FST					NR?	4
	LIP				LIP			M	D		4
	VIP		F	A	VIP						4
	FEF	S		A	FEF						5
TF		F	A	TF		I		D	A-D	7	
V3A	V4	B	F	A	V4	V3A		M	D	A-D	1
	MT	B	F	A	MT		I	C/M	D/L?		1
	PO	B		u	PO						1
	DP	S/B		A?	DP			M	D	A-D?	2
	MSTd	S/B		A?	MSTd			M	D	A-D?	3
	MSTl	S/B		A?	MSTl			M	D	A-D?	3
FST	S		A	FST			M	D	A-D	3	

Table 5
Continued

13	14	15	16	17	18
Output References*			Input References*		
Origin	Termination	Special (E, R, S, A)	Origin	Termination	Special (E, R, S, A)
LH, '84 BFNV, '86	RP, '79 C, '69 Z, '80 Z, '80	E: VNMB, '86 E: Z, '78a A: UD, '86a; VNMB, '86	VNMB, '86 PBK, '86 PBK, '86	RP, '79 FV, '84	R: VNMB, '86 E: PBK, '86 R: VNMB, '86
YI, '85			PBK, '86 PBK, '86	YI, '85	
MV, '83 CGDG, '88 BUD, '90	UD, '86a	A: VNMB, '86	PBK, '86	MV, '83	E: VNMB, '86 A: PBK, '86
FV, '84 BV, '83 BV, un	UGSM, '83 NMV, '86 Z, '78b		NMV, '86	FV, '84 BV, '83 FV, un	
DV, '85	UGSM, '83	E: NMV, '86	RP, '79	FV, '83	E: NMV, '86
FDKOV, '88 DV, '85 CGDG, '88 BUD, '90 BUD, '90 BUD, '90	UD, '86a UD, '86a UD, '86a		RP, '79	MV, '83 BUD, '90 BUD, '90	A: BUD, '90
B, '88		S: NMV, '86; R: BUD, '90 E: NMV, '86 A: HKK, '87			
FV, '83 FDKOV, '88 MV, '83 CGDG, '88 BUD, '90 BUD, '90	FV, '84 FBV, '87 FV, '84 FV, '84 FV, '84 FV, '84 FV, '84 FV, '84	R: BUD, '90	FV, '84 FV, '84 FBV, '87 FV, '84 FV, '84 FV, '84 FV, '84 FV, '84	FV, un FV, '83 MV, '83 BUD, '90	R: BUD, '90 R: BUD, '90
B, '88	FV, '84 FV, '84	A: HKK, '87	FV, '84 FV, '84 FV, '84		
FV, '84 UD, '86b CGDG, '88 BUD, '90 BUD, '90	BV, '83 BV, '83 BV, '83 BV, '83 BV, '83 BV, '83 BV, '83	R: BUD, '90	BV, '83 BV, '83 BV, '83 BV, '83 BV, '83	FV, '84 MV, '83 AAES, '90	A: BV, '83 R: BUD, '90 A: BUD, '90
B, '88	BV, '83 BV, '83	A: HKK, '87	BV, '83		
FV, '84 UD, '86b CGDG, '88 AAES, '90 BUD, '90 BUD, '90 BUD, '90	FV, un FV, un		FV, un	FV, '84 UD, '86b AAES, '90 BUD, '90 BUD, '90 BUD, '90	A: MV, '83

Table 5
Continued

1	2	3	4	5	6	7	8	9	10	11	12
Outputs					Inputs					Hierarchical relationship	Levels crossed
From	To	Origin (S, B, I)	Termination (F, C, M)	Direction (A, L, D)	From	To	Origin (S, B, I)	Termination (F, C, M)	Direction (A, L, D)		
V3A (cont'd)	LIP FEF	S		A	LIP FEF	V3A (cont'd)	I	M	D		
PIP	V4 MT PO DP 7a	B S S/B B		u u A A? u	V4 MT PO DP 7a	PIP		M M	D u D		1 1 1 2 4
PO	V4t MT MIP MDP DP MSTd MSTl LIP VIP 7a FEF	B S/B? S S S S/B S		u A? A A A u A? A	V4t MT MIP MDP DP MSTd MSTl LIP VIP 7a FEF	PO	B B B B B B B B	C/M C/M? M M C/F M(I)	u L/D? u u L/D? D D L/A? u D? u		0 0 0 0 1 2 2 2 2 3 3
V4	V4t MT VOT DP LIP FST PITd PITv CITd CITv AITv FEF TF TH 46	B S/B B S S S S S S S S	F/C C F F F F F	L/A? L/A? u A A A A A A A A? A A A	V4t MT VOT DP LIP FST PITd PITv CITd CITv AITv FEF TF TH 46	V4	B B B B B I I	C/M M M M M M	u L/D? D D D D D D u D D	L-L?	0 0 1 1 2 2 2 2 3 3 4 3 5 5 5
V4t	MT MSTd MSTl FST FEF	B S S S		u A? A A	MT MSTd MSTl FST FEF	V4t	B B B	C M M	L D? D		0 2 2 2 3
MT	MSTd MSTl FST LIP VIP FEF 46	S/B S/B S/B S S	F F F	A A A u A A	MSTd MSTl FST LIP VIP FEF 46	MT	B/I B/I I B	M M M M M?	D D D D u D?	A-D	2 2 2 2 2 3 5
MIP	7a	B		u	7a	MIP					3
MDP	7a	B		u	7a	MDP					3
VOT	PITd PITv		F F	A A	PITd PITv	VOT					1 1

Table 5
Continued

Output References*			Input References*		
Origin	Termination	Special (E, R, S, A)	Origin	Termination	Special (E, R, S, A)
B, '88		A: HKK, '87	AAES, '90	BSA, '87	
FBV, '87		E: UD, '86b		FV, '84	E: UD, '86b
CGOG, '88 AAES, '90 AAES, '90				AAES, '90	
UD, '86b			CGOG, '88 CGOG, '88 CGOG, '88 CGOG, '88	UD, '86b	A: MV, '83
AAES, '90 BUD, '90 BUD, '90 BSA, '87		E: SP, '80	CGOG, '88 CGOG, '88 CGOG, '88 BSA, '87	AAES, '90 BUD, '90 BUD, '90 AAES, '90	
CG, '89; AAES, '90 B, '88		A: HKK, '87		AAES, '90	S: CGOG, '88
FDKOV, '88 MV, '83; UD, '86a	FV, '83 FV, '83		FV, '83 FV, '83 FKV, '86	MV, '83; UD, '86a FV, '84 AAES, '90 BSA, '87	
AAES, '90	BSA, '87		FV, '83	AAES, '90 BSA, '87	
BUD, '90 DFG, '80 DFG, '80 DFG, '80 DFG, '80	FKV, '86 FKV, '86 FKV, '86 FKV, '86		VFDOK, '91 VFDOK, '91 VFDOK, '91 VFDOK, '91 VFDOK, '91	BUD, '90 RP, '79 RP, '79	
F, '86 BM, '81		A: HKK, '87			E: F, '86
BM, '81	FKV, '86 FKV, '86	S: B, '88	FKV, '86 FKV, '86	RP, '79	
UD, '86b			FDKOV, '88 FDKOV, '88	UD, '86b BUD, '90	R: BUD, '90
BUD, '90 BUD, '90 B, '88		R: BUD, '90 A: HKK, '87	FDKOV, '88	BUD, '90	
BUD, '90	MV, '83		MV, '83; UD, '86b	BUD, '90	
BUD, '90	MV, '83		MV, '83; UD, '86b	BUD, '90	
BUD, '90 BSA, '87	UD, '86b		UD, '86b	BUD, '90 BSA, '87	
B, '88 B, '88	MV, '83 UD, '86b	A: UD, '86b; S: B, '88	UD, '86b	HKK, '87	A: UD, '86b A: UD, '86b
AAES, '90 AAES, '90					
	FV, un FV, un				

Table 5
Continued

1	2	3	4	5	6	7	8	9	10	11	12	
Outputs						Inputs					Hierarchical relationship	Levels crossed
From	To	Origin (S, B, I)	Termination (F, C, M)	Direction (A, L, D)	From	To	Origin (S, B, I)	Termination (F, C, M)	Direction (A, L, D)			
DP	FST			u	FST	DP					1	
	LIP		C/F	L/A?	LIP	B	C/M	L/D?	L-L?	1		
	MSTd	S/B		A?	MSTd	B	C	L	NC?	1		
	MSTI	S		A?	MSTI				NR?	1		
	7a	B	F	A	7a	B	M	D		2		
	FEF				FEF			u		2		
	46		F	A	46			u		4		
FST	MSTd	S/B	C	L/A?	MSTd	FST	B	M/C	L/D?	L-L?	0	
	MSTI	B	C	L	MSTI	B	C/F	L/A?	L-L?	0		
	PIT		M/C	D/L?	PIT	B		u		0		
	LIP	B	C/M?	L/D?	LIP	B		u		0		
	VIP		M/C	D/L?	VIP	B		u		0		
	FEF	S	F/M	A/D?	FEF	I		D		1		
	7a	B		u	7a					1		
	STPp		F	A	STPp	I		D	A-D	1		
	TF		C	L	TF	B/S		A?	NC?	3		
VIP	MSTd	B		u	MSTd	VIP		C	L		0	
	MSTI	B		u	MSTI			C/M	L/D?		0	
	LIP			u	LIP				u		0	
	FEF	B		u	FEF			M	D		1	
	7a	B		u	7a						1	
LIP	MSTd	B	C/F	L/A?	MSTd	LIP	B	C	L?	L-L?	0	
	MSTI	B		u	MSTI						0	
	PITv		C?	L?	PITv						0	
	7a	B		u	7a			M	D		1	
	FEF	S	F	A	FEF			M	D	A-D	1	
	TF		F/C?	A/L?	TF						3	
46	S	F	A	46						3		
MSTd	7a	B	C	L	7a	MSTd	B	M	D	NC	1	
	PIT	S?		A?	PIT	B		u			0	
	TF				TF	I		D			3	
	FEF	S	F	A	FEF	I		D	A-D	1		
	STPp		F	A	STPp	I/B		D	A-D	1		
MSTI	7a				7a	MSTI	B		u	NR?	1	
	FEF	S	F	A	FEF	I		D	A-D	1		
	STPp		F	A	STPp	I/B		D?	A-D?	1		
PIT	FEF	S		A	FEF	PIT					1	
	46	S		A	46						3	
PITd	CITv	S/B		A?	CITv	PITd					1	
	AITd	S/B		A?	AITd						2	
	AITv	S/B		A?	AITv						2	
PITv	CITd				CITd	PITv	I/B		D?		1	
	CITv	S/B		A?	CITv	I/B		D?	A-D?	1		
	AITd				AITd	I/B		D?		2		
	AITv	S/B		A?	AITv	I/B		D?	A-D?	2		
	TF				TF	I/B		D?		3		
TH				TH	I		D		3			
CIT	STPp				STPp	CIT		C	L		0	
	TH				TH		I		D		2	
	FEF	S		A	FEF		S/B		A?	NC?	0	
46	S		A	46		S/B	M	A/D?	NC?	2		
CITd	AITd	S/B		A?	AITd	CITd					1	
	AITv	S/B		A?	AITv						1	

Table 5
Continued

1	2	3	4	5	6	7	8	9	10	11	12
Outputs					Inputs					Hierarchical relationship	Levels crossed
From	To	Origin (S, B, I)	Termination (F, C, M)	Direction (A, L, D)	From	To	Origin (S, B, I)	Termination (F, C, M)	Direction (A, L, D)		
CITv	AITd	S/B		A?	AITd	CITv	I/B		D?	A-D?	1
	AITv	S/B		A?	AITv		I/B		D?	A-D?	1
	TF				TF		I		D		2
7a	AITd		F	A	AITd	7a	B		u		1
	STP		F/M?	A/D?	STP		B/I		u	NC?	1
	TF		F	A	TF		I/B		D?	A-D?	2
	TH		F	A	TH		I		D	A-D	2
	FEF	B	C/M?	L/D?	FEF		B		u		0
46	B	F/C	A/L?	46		B/S	M		D?		2
FEF	AITd	S		A	AITd	FEF		M(s)	D?	A-D?	1
	STPp	B	M(s)	D?	STPp		B	M(s)	D?	NC	0
	46	B	F/C	A/L?	46		B		u		2
STPp	STPa	S	F	A	STPa	STPp	I	M	D	A-D	1
	TF			u	TF		I		D		2
	TH			u	TH		I		D		2
	46	S	C	A/L?	46		S	M	A/D?	NC	2
STPa	TF			u	TF	STPa	I		D		1
	TH			u	TH		I		D		1
	46	S		A	46			M	D	A-D	1
AITd	STPa				STPa	AITd	B		u		0
	TF				TF				u		1
	TH				TH				u		1
AITv	TF		F	A	TF	AITv	I		D	A-D	1
	TH		F/C	A/L?	TH		I		D	A-D?	1
46	AITd	S		A	AITd	46		M(s)	D?	A-D?	1
	TF		M/C	D/L?	TF		B		u		0
	TH		C	L?	TH		I/B		D?	NC?	0

This table shows connections among visual cortical areas listed in Table 1. Each row deals with pairs of a reciprocal linkage with the outputs listed in columns 1-5 and the inputs listed in columns 6-10. For each pathway, the laminar origin (S, supragranular; B, bilaminar; I, infragranular), laminar pattern of termination (F, layer 4 predominant; C, columnar; M, multilayer avoiding layer 4), and pathway direction (A, ascending; L, lateral; D, descending) is listed when known. The symbol "u" indicates the pathway has been demonstrated but the laminar features are unknown. Columns 11 and 12 refer to the hierarchical relationships between the pairs of areas. A-D indicates an ascending-descending pair where the lamina; patterns of connections in both directions are consistent with a hierarchical pairing extending across layers of a hierarchy. Level indicates the number of hierarchical levels the pathway traverses (in either direction) in the hierarchy illustrated in Figure 4. Columns 13-15 and 16-18 provide references to each of the illustrated input and output pathways, respectively. Columns 15 and 18 provide pathway information: E, the existence of a pathway without laminar information; R, rare pathway; S, sparse pathway; A, absent pathway. Only those pathways whose absence provides some controversy are listed in this column.

* Reference key (italic signifies abstracts or unpublished observations):

AAES, '90	Andersen, Asanuma, Essick, and Siegel, 1990	DV, '85	DeYoe and Van Essen, 1985
B, '85	Brady, 1985	F, '86	Fenstermaker, 1986
B, '86	Barbas, 1986	FBV, '87	Felleman, Burkhalter, and Van Essen, 1987
B, '88	Barbas, 1988	FDKOV, '88	Felleman, DeYoe, Knerim, Olavarria, and Van Essen, 1988
BFNV, '86	Burkhalter, Felleman, Newsome, and Van Essen, 1986	FKV, '86	Felleman, Knerim, and Van Essen, 1986
BM, '81	Barbas and Mesulam, 1981	FV, '83	Felleman and Van Essen, 1983
BM, '85	Barbas and Mesulam, 1985	FV, '84	Felleman and Van Essen, 1984
BP, '89	Barbas and Pandya, 1989	FV, un	D. J. Felleman and D. C. Van Essen, unpublished observations
BSA, '87	Blatt, Stoner, and Anderson, 1987		
BUD, '90	Boussaoud, Ungerleider, and Desimone, 1990	GSS, '84	Goldman-Rakic, Selemon, and Schwartz, 1984
BV, '83	Burkhalter and Van Essen, 1983	HKK, '87	Huerta, Krubitzer, and Kaas, 1987
BV, un	A. Burkhalter and D. C. Van Essen, unpublished observations	KA, '77	Künzle and Akert, 1977
C, '69	Cragg, 1969	L, '80	Leichnetz, 1980
CGOG, '88	Colby, Gattass, Olson, and Gross, 1988	LH, '84	Livingstone and Hubel, 1984a
CG, '89	Cavada and Goldman-Rakic, 1989a	MV, '83	Maunsell and Van Essen, 1983
DFG, '80	Desimone, Fleming, and Gross, 1980	MVPG, '77	Mesulam, Van Hoesen, Pandya, and Geschwind, 1977

Table 5
Continued

13	14	15	16	17	18	
Output References*			Input References*			
Origin	Termination	Special (E, R, S, A)	Origin	Termination	Special (E, R, S, A)	
F, '86 S, '87			S, '87 S, '87 SP, '87			
	L, '80 SGR, '88; CG, '89; AAES, '90 SP, '84; CG, '89 SP, '84	E: AAES, '90	AAES, '90 MVPG, '77; CG, '89; AAES, '90 MVPG, '77; CG, '89 MVPG, '77; CG, '89 AAES, '90			
BM, '81	L, '80; AAES, '90	A: HKK, '87				
BM, '81	L, '80		AAES, '90	SG, '84		
SP, '89a B, '88	SP, '89a KA, '77 HKK, '87; BP, '89	E: KA, '77	SP, '89a BM, '81; HKK, '87 B, '88	SP, '89a		
SP, '89b	SP, '89b	E: SP, '87 E: SP, '87	SP, '89b B, '85 B, '85 SP, '89a	SP, '89b		
BM, '85	SP, '89a	E: SP, '87 E: SP, '87	B, '85 B, '85	SG, '88		
BM, '85				SG, '88		
			F, '86		E: F, '86 E: F, '86	
	SP, '76 SP, '76		S, '87 S, '87			
SP, '89a				SP, '89a		
	GSS, '84; SG, '88 GSS, '84		GSS, '84 GSS, '84			
NMV, '86 PBK, '86 RP, '79 S, '87 SG, '84 SG, '88 SP, '76 SP, '80 SP, '84 SP, '87 SP, '89a	Newsome, Maunsell, and Van Essen, 1986 Perkel, Bullier, and Kennedy, 1986 Rockland and Pandya, 1979 Shiwa, 1987 Schwartz and Goldman-Rakic, 1984 Selemon and Goldman-Rakic, 1988 Seltzer and Pandya, 1976 Seltzer and Pandya, 1980 Seltzer and Pandya, 1984 Seltzer and Pandya, 1987 Seltzer and Pandya, 1989a		SP, '89b UD, '86a UD, '86b UGSM, '83 VFDOO, '91 VNMB, '86 YI, '85 Z, '78a Z, '78b Z, '80	Seltzer and Pandya, 1989b Ungerleider and Desimone, 1986a Ungerleider and Desimone, 1986b Ungerleider, Gattass, Sousa, and Mishkin, 1983 Van Essen, Felleman, DeYoe, Olavarria, and Knierim, 1991 Van Essen, Newsome, Maunsell, and Bixby, 1986 Yukie and Iwai, 1985 Zeki, 1978a Zeki, 1978b Zeki, 1980		

Table 6
Irregular and mismatched connectivity patterns

Irregular Terminations			Origin-Termination Mismatches				
From	To	Pattern	From	To	Origin	Termination	
VP	V3A	F/C	V4	MT	S/B	C	
MT	V3A	C/M	FST	MSTd	S/B	C	
DP	PO	C/M?	STPp	46	S	C	
LIP	PO	C/F	46	CIT	S/B	M	
MT	PO	C/M	46	7a	B/S	M	
V4	V4 _l	F/C	46	STPp	S	M	
MT	V4	C/M					
DP	LIP	C/F					
LIP	DP	C/M					
MSTl	FST	C/F					
MSTl	VIP	C/M					
MSTd	FST	M/C					
FST	PIT	M/C					
FST	VIP	M/C					
FST	LIP	C/M?					
FST	FEF	F/M					
LIP	MSTd	C/F					
LIP	TF	F/C?					
FEF	46	F/C					
7a	STP	F/M?					
7a	FEF	C/M?					
7a	46	F/C					
AITv	TH	F/C					
46	TF	M/C					

architecturally defined FEF. The remaining 22 irregular patterns are all C/F or C/M mixtures and therefore involve an apparent conflict of only one step (lateral vs. ascending or lateral vs. descending). We suspect that this bias for C/F and C/M patterns is not a coincidence and that it may be important for understanding the significance of mixed or intermediate termination patterns (see below).

Step 2: Matching Origins and Terminations

The next step is to assess the consistency of retrograde and anterograde patterns for the 88 pathways in which both types of laminar information are available. In 39 of these cases, the retrograde pattern is bilaminar and hence is compatible with any anterograde pattern. There are 26 S→F and 8 I→M combinations, both of which are strongly consistent with an orderly hierarchical relationship. In addition, most of the 16 cases with mixed patterns on either the retrograde or the anterograde side also are fully consistent with this scheme (e.g., S/B→F, etc.). In a few cases, however, there are possible hierarchical inconsistencies, which are listed separately as "origin-termination mismatches" in Table 6. In 4 instances, the assignment for the origin is mixed (S/B). If further investigation reveals that these are B patterns, then there would be no conflict with the C or M terminations. If, on the other hand, any of them turn out to be S patterns, it would be an overt conflict with the criteria we have used. In the remaining 2 cases (area 46 to STPp and STPp to 46), the reported origin is an explicitly (S) pattern giving rise to an M or C termination pattern (Barbas and Mesulam, 1985; Selemon and

Goldman-Rakic, 1988; Seltzer and Pandya, 1989a). It will be important to reexamine these pathways using combined retrograde and anterograde tracers and injections unequivocally restricted to a single visual area.

Step 3: Reciprocal Relationships

Analysis of reciprocal pathways provides the next test of the consistency of hierarchical relationships. From the data in column 11 of Table 5, there are 65 linkages in which the pattern is explicitly identifiable as ascending in one direction and descending in the other (49 designated as A-D, 16 designated as A-D?). There are only 5 linkages that are identifiably lateral in both directions (L/L), and all of these are questionable in one way or another. There are also 10 possible exceptions to this pattern, which are listed as "reciprocity mismatches" in Table 6 and also are indicated by "NC" or "NC?" (not consistent) in column 11 of Table 5.

In nearly all of the irregular cases (9 of 10), the comparison involves hierarchical assignments that are questionable on 1 or more counts, owing to the types of uncertainties described in the preceding 2 sections. Thus, while these putative counterexamples should be taken seriously, they should not all be regarded as present as unequivocal violations of our scheme. The strongest case for a genuine violation is the linkage between MSTd and 7a, which is reported to be descending from 7a to MSTd but lateral in the reverse direction (Andersen et al., 1990; Boussaoud et al., 1990).

Table 6
Continued

Reciprocity Mismatches

Pathway	Direction	Pathway	Direction	Hierarchical Mismatches
PO-LIP	A	LIP-PO	L/A?	FST-TF
DP-MSTd	A?	MSTd-DP	L	MSTd-PIT
FST-TF	L	TF-FST	A?	AITd-46
MSTd-7a	L	7a-MSTd	D	
CIT-FEF	A	FEF-CIT	A?	
CIT-46	A	46-CIT	A/D?	
7a-STP	A/D?	STP-7a	D?	
FEF-STPp	D?	FEF-STPp	D?	
STPp-46	A/L?	46-STPp	A/D?	
46-TH	L?	TH-46	D?	

Step 4: Global Hierarchical Constraints

We now address whether these pairwise relationships can be used to generate an overall hierarchy involving the entire collection of visual areas and pathways. To avoid logical inconsistencies, each area must be placed above all areas from which it receives ascending connections and/or sends descending connections. Likewise, it must be placed below all areas from which it receives descending connections and/or sends ascending connections. Finally, if an area has lateral connections, these must be with other areas at the same hierarchical level. All of the information needed to construct such a hierarchy is contained within Table 5, but it is not formatted optimally for the task. We therefore created an intermediate tabulation that greatly facilitated the process (Table 7).

Table 7 represents a "constraint chart" that indicates, for each visual area, all of the other areas with which it is connected and the hierarchical relationships that can be inferred solely on the basis of their direct linkages. For example, based only on what is known about its own connections, MT is unequivocally at a lower level than 7 areas (VIP, LIP, FST, MSTd, MSTl, FEF, and 46), level with 1 area (V4t), and higher than 4 areas (V1, V2, V3, and VP). In addition, MT is constrained to be level with or higher than areas V3A, V4, and PO, based on the mixed pattern of connectivity with those areas. Finally, MT has a known connection with area PIP that provides no constraints at all, making their hierarchical relationship indeterminate.

Once all of these pairwise relationships were tabulated, we began the task of generating an internally consistent hierarchy. This was done in a "bottom-up" fashion, by progressively adding areas to successive stages on the basis of information contained in the "higher than" and "level with" columns of Table 7. The sequence begins by identifying the area, namely V1, that has no entries in the "higher than" or "level with" categories and must therefore be at the lowest hierarchical level. The next level is populated by the area, namely V2, whose listing of "higher than" includes only the lowest area, V1. The process continues iteratively by adding at the next stage only areas whose listing of "higher than" includes those areas

already entered in the emerging hierarchy. If more than 1 entry at a given level occurs, it is critical that they either be unconnected or be connected by lateral or indeterminate pathways. In cases where the constraint chart only partially restricts the positioning of areas (e.g., MT is level with or higher than V4), we chose the configuration that left all areas in the lowest possible state and minimized inconsistencies within the overall hierarchy. The resultant choices for these flexible cases are indicated by entering the linkage in the appropriate subcolumn within Table 7. This process continues iteratively until all hierarchical levels are established. Once the positioning of all areas is achieved, the wiring diagram can be added by inclusion of all linkages listed in the constraint table.

The hierarchical scheme that results from this analysis is shown in Figure 4. It includes all of the 32 visual cortical areas organized into 10 hierarchical levels. Each visual area is represented by a box colored in the same shade as on the cortical map (Fig. 2). In addition, we have included at the bottom the 2 subcortical levels (retina and LGN) that represent the primary source of visual inputs to the cortex. Finally, we have included at the top several uncolored entries that represent some of the linkages of the visual system to other sensory modalities and to "higher" associational cortex (see below).

As already noted, the coloring scheme for different areas provides information about the geographical location and the cortical processing stream in which they reside. In the upper part of the hierarchy, orange and yellow hues represent parietal areas, green hues represent temporal areas, and brown hues represent frontal areas. For the areas in the occipital lobe (lower part of Fig. 4), the primary distinction is between the M (magnocellular) stream (red and pink areas) and components of the P (parvocellular) stream (purple, blue, and violet). The P stream can be further split into the P-B (parvo-blob) and P-I (parvo-interblob) streams of V1 and V2 (see DeYoe and Van Essen, 1988). Connections of V1 and V2 that can be assigned explicitly to components of these streams are indicated appropriately in the figure; those that have not been specifically linked are represented by the lines emerging from the generically labeled boxes in V1

Table 7
Hierarchical constraints

Area	Lower than	Lower	or	Level	Level with
V1	V2, V3, V3A, PIP, V4, V4t, MT, PO, MSTI?				
V2	V3, VP, V3A, V4, V4t, MT, PO, MSTd, MSTI, FST, FEF				
V3	V3A, PIP, V4, V4t, MT, PO, MSTd, FST, LIP, VIP, FEF, TF				
VP	PIP, V4, PO, MT, VOT, MSTd, FST, LIP, VIP, FEF, TF	V3A			
V3A	V4, DP, MSTd, MSTI, FST, LIP, FEF	MT			
PIP	V4, PO, DP				
PO	MSTd, MSTI, 7a, FEF	DP		MT	
V4	VOT, DP, LIP, FST, PITd, PITv, CITd, CITv, FEF?, AITv, TF, TH, 46			MT, V4t	
V4t	MSTd?, MSTI?, FST, FEF				MT
MT	MSTd, MSTI, FST, LIP, VIP, FEF, 46				V4t
MIP					
MDP					
VOT	PITd, PITv				
DP	MSTI?, 7a, 46	MSTd			
FST	STPp	LIP		MSTd	
VIP	FEF			MSTI, FST	MSTd
LIP	7a, FEF, 46	TF		MSTd, FST	PITv
MSTd	FEF, STPp, PIT?, TF	7a			VIP
MSTI	FEF, STPp			FST	
PIT	FEF, 46			FST	
PITd	CITv?, AITd?, AITv?				
PITv	CITd?, CITv?, AITd?, AITv?, TF?, TH				LIP
CIT	TH				STPp
CITd	AITd?, AITv?				
CITv	AITd?, AITv?, TF				
7a	AITd, TF, TH	46?		FEF	
FEF	AITd	46			
STP					
STPp	STPa, TF, TH				CIT
STPa	TF, TH, 46				
AITd					
AITv	TF, TH				
46	AITd			TH	
TF				FST, 46	
TH					

and V2. A similar strategy is used to represent connections between regions representing more than a single area in our partitioning scheme. For example, there are connections of PIT that cannot yet be assigned specifically to PITd or PITv. The connection between 7a and STP is also of this type, but we have

shown this as a linkage with STPa in particular, in order to avoid the complications of an STP entry that would have to be placed between 2 levels. Areas MIP and MDP have been placed at the fifth hierarchical level, even though the connections known for both areas are ambiguous (bilaminar retrograde labeling)

Table 7
Continued

Level	or	Higher	Higher than	Indeterminant
			V1	VOT, PIP, VIP
			V1, V2	VP
			V2	V3
		VP	V1, V2, V3 V1, V3, VP V1, V2, V3, VP, PIP V1, V2, V3, VP, V3A, PIP	PO V2, MT, 7a V3A, V4t, MIP, MDP, VIP, LIP
V4 V4, PO		V3A	V1, V2, V3 V1, V2, V3, VP	PO PIP
		PO	VP, V4 V3A, PIP, V4	PO, 7a PO, 7a V2 FST, FEF
PIT, LIP, VIP, MSTI, TF			V2, V3, VP, V3A, V4, V4t, MT V3, VP, MT	DP, 7a, FEF V2, PO, LIP, 7a
FST, LIP	DP DP		V3, VP, V3A, V4, MT V2, V3, VP, V3A, V4t?, MT, PO V1?, V2, V3A, MT, PO, V4t?, DP? MSTd? V4, VOT V4, VOT	PO, VIP, MSTI LIP, 7a
		MSTd	V4, PITv V4, PITd, PITv PO, DP, LIP V2, V3, VP, V3A, PO, V4?, V4t, MT, MSTd, MSTI, VIP, LIP MSTd, MSTI, FST STPp	FEF, 46 PIP, VIP, FST, MSTI, STP, MIP, MDP DP, CIT, FST, STPp 7a FEF, 46 AITd
TF	7a?, FEF LIP		7a, FEF, PITd?, PITv?, CITd?, CITv?, 46 V4, PITd?, PITv?, CITd?, CITv? V4, MT, DP, LIP, PIT, STPa V3, VP, V4, PITv, MSTd, CITv, AITv, 7a, STPp, STPa V4, PITv, CIT, AITv, STPp, STPa, 7a	STPa, TF, TH CIT, STPp AITd AITd
46				

and would technically be consistent with placement at any lower level. This assignment is obviously provisional, pending additional connectivity information. However, it would be surprising if either MDP or MIP ultimately ended up at a lower level, because there is a strong tendency for areas positioned more

anteriorly in the cortex (to the right on the cortical map) to be situated at higher levels of the hierarchy.

This hierarchy is consistent with all but 3 of the relationships listed in the constraint chart. One exception is the linkage between FST and TF, which constrains TF to be level with or lower than FST

in many places to trace the lines representing specific pathways. In order to permit inspection and updating of these connections in a flexible manner, we created the hierarchy on a graphics drawing program (CANVAS) that runs on Macintosh computers. Each area and all of its connections are represented in a different "layer" that can be independently switched on or off, thereby allowing easy visualization of any desired subset of the overall hierarchy.

The current hierarchy is more extensive than, but otherwise largely consistent with, recently published hierarchical schemes that have been based on similar anatomical criteria (Van Essen, 1985; Andersen et al., 1990; Boussaoud et al., 1990). However, there are a few significant differences that merit explicit mention. Our new version differs from the Van Essen (1985) scheme in having area 7a moved 1 step higher and area DP 1 step lower. The differences with the Andersen et al. (1990) scheme are slightly greater: (1) We have DP 1 step lower and PO 2 steps lower than in theirs; (2) we have MSTd/l level with LIP, rather than above it; (3) instead of a single area IT sitting above 7a, we have multiple subdivisions of IT, and AITd/v above and CITd/v level with 7a; and (4) instead of a single STP, we have STPp and STPa, with only the former being level with 7a. The differences with the Boussaoud et al. (1990) scheme include (1) our positioning of areas V3A and DP each at 1 stage lower than in theirs, (2) our positioning of 7a at 1 stage higher than their PP/IPG, and (3) our positioning of TF several stages higher than in theirs. In most instances, these differences can be traced to the way in which different investigators have interpreted the various irregularities and conflicts that we have already discussed in connection with Table 6.

Significance of Hierarchical Irregularities

The red lines in Figure 4 indicate the 33 linkages having one or another of the hierarchical irregularities discussed in connection with Table 6. Their presence raises the issue of whether the cortex is inherently only a "quasi-hierarchical" structure that contains a significant number (perhaps 10%) of bona fide irregularities and exceptions to any set of criteria that can be devised. Alternatively, the visual cortex might contain an essentially perfect anatomical hierarchy that has been imperfectly studied using inherently "noisy" methods of anatomical analysis. Either interpretation is an interesting one, in our opinion, but we doubt that it is possible to obtain a clear-cut answer on the basis of currently available data.

The anatomical data on which our analysis is based are often fuzzy and replete with uncertainties of one or another type. Thus, it would have defied the odds if every single one of the 305 pathways had fit precisely into an orderly hierarchy. It is very likely that at least a few of the laminar and hierarchical assignments cited in our analysis will change when additional experimental data become available. If one suspects that the underlying biology is extremely orderly, one would predict that the apparent discrepancies listed in Table 6 will largely disappear upon careful

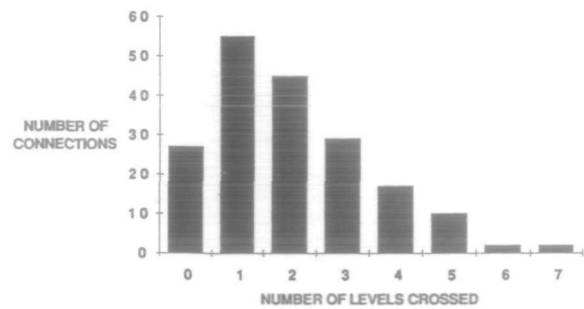

Figure 5. Histogram of number of hierarchical levels traversed by different pathways. Most pathways traverse only 1 or 2 levels, but a few ascend or descend as many as 6 or 7 levels.

reexamination, thereby improving the overall fit to the hierarchy. This might be accompanied by changes in some of the specific hierarchical assignments. If, on the other hand, one suspects that a hierarchical relationship merely reflects a strong statistical bias, the prediction would be that an increasing number of unambiguous inconsistencies with our scheme will be found. This is a matter of speculation at the moment, and we do not take a strong stand on either side, except to emphasize that the issue is amenable to experimental validation or refutation. To distinguish incisively among different alternatives, however, it is crucial that reports of anatomical connectivity be as precise and quantitative as possible with regard to basic questions of (1) the confidence with which sources and targets have been identified in relation to areal boundaries and (2) the exact laminar distribution of anterograde and retrograde tracers.

As a reminder, we note that about 10% of the pathways shown in Figure 4 are distinctive in terms of being sparse, occasional, or controversial in nature, and a somewhat larger percentage is based on information currently available only in abstracts. We found that resolution limits made it impractical to flag these special cases by distinctive colors in the figure, but they can nonetheless be readily tracked down with reference to Tables 3 and 5.

Number of Levels Traversed

While some pathways link areas at the same or immediately adjacent hierarchical levels, the majority of pathways traverse more than 1 level. For example, V1, at the first cortical level, projects to areas at the next 4 levels, from the second (V2) to the fifth (MT). The extreme limit is represented by the projections from areas V3 and VP (level 3) to parahippocampal areas TF and TH (level 10), thereby traversing 7 hierarchical levels. Moreover, because V3 receives direct inputs from V1, it is, in principle, possible for signals to span the entire visual hierarchy with only 1 relay. The route from V1 to MT to area 46 provides another example of this type.

A systematic analysis of this issue is shown in Figure 5a, which is a histogram of the number of levels separating all pairs of visual areas known to be interconnected. The mean value is 1.8 levels. Signals that traversed the hierarchy at approximately this rate

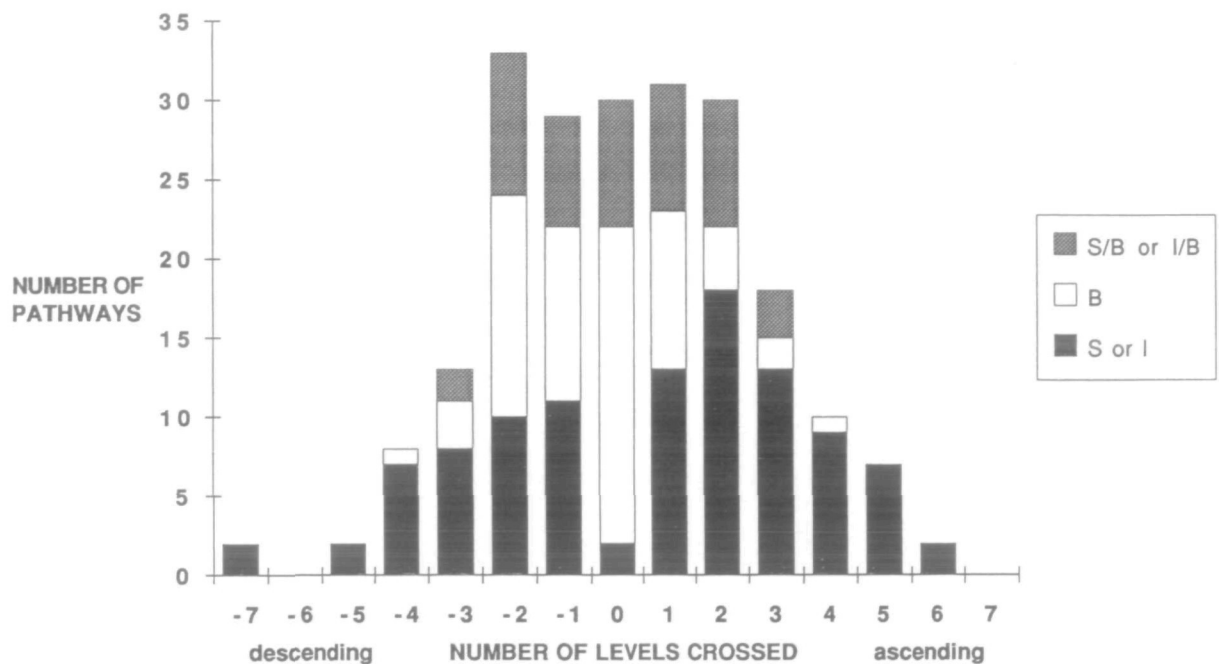

Figure 6. Relationship of laminar patterns for cells of origin to number of levels traversed. The great majority of bilaminar patterns (open regions) arise from pathways traversing no more than 2 levels, whereas unilaminar patterns are encountered over the entire range and are especially predominant for pathways traversing 3 or more levels.

would pass through 5 or 6 stages between start and finish.

Given that ascending pathways and descending pathways can both be associated with a retrograde labeling pattern that can be either bilaminar or unilaminar (supragranular for ascending, infragranular for descending), we wondered whether there was anything systematic about the occurrence of one or the other pattern. Figure 6 shows that there is an interesting difference along these lines. Descending and ascending pathways are indicated, respectively, by negative and positive values for the number of levels crossed. Pathways originating from unilaminar patterns are indicated by solid bars, those of bilaminar origin are indicated by open bars, and the mixed assignments (S/B and I/B) are indicated by shading. There is considerable overlap between bilaminar and unilaminar populations. Nonetheless, it is apparent that the more specific unilaminar projections, on average, traverse more hierarchical levels than do the bilaminar projections: 2.68 levels for I patterns, 2.76 levels for S patterns, and 1.71 levels for B patterns, excluding all of the lateral pathways. These differences (S vs. B; I vs. B) are highly significant ($p < 0.005$, Student's *t* test). Stated differently, a majority (60%) of the pathways traversing only 1 level are of bilaminar origin, whereas a majority (66%) of those traversing 2 or more levels are of unilaminar origin.

In the anterograde direction, it is instructive to consider the subset of pathways that show mixed, or borderline, termination patterns (C/M and C/F patterns in Tables 5, 6). On average, these pathways traverse less than 1 level (~ 0.8), which is less than half what would be expected if they were picked randomly from the overall pool. Thus, it appears that, in both

retrograde and anterograde directions, differences in laminar patterns are statistically correlated with the number of levels separating any given pair of areas, as well as the sign (ascending, descending, or lateral) of the relationship.

A related set of questions arises when considering connectivity patterns and hierarchical relationships among adjacent visual areas, that is, ones that share a common boundary in the intact cortex. In terms of connectivity, the great majority of areas that adjoin one another are directly and reciprocally interconnected. There are only a few clear-cut exceptions, such as the reported lack of a connection between ventral area V2 and adjoining areas TF and TH. Thus, while many pathways connect areas that are widely separated within the cortex, it is rare to see adjoining areas that fail to communicate directly with one another.

In terms of hierarchical relationships, the majority of adjoining areas are either at the same level or are separated by only 1 level. However, there are numerous examples of neighboring areas separated by 2 or 3 levels (e.g., V2/V4, VP/V4, and PIP/VIP). The maximum hierarchical jump between neighbors is the 8 steps between V2 and TF/TH, but very few others are separated by more than 1 level.

Finally, the tendency for areas more anterior in the cortex (to the right on the map in Fig. 2) to be at a higher level, or at least the same level, is quite striking. This geographical relationship was pointed out by Rockland and Pandya (1979), at a time when only a handful of well-defined areas were known, and our point here is simply that the trend persists even at the much finer grain of analysis now available. However, there are a few specific counterexamples, such

as the fact that TF and TH are posterior to, but at a higher level than, AITd and AITv, and likewise for 7a versus MT, MSTd, MSTl, and FST. With the exception of MDP and MIP (see above), these geographical considerations played absolutely no role in the formulation of the cortical hierarchy, so we regard the "anterior signifies upwards" trend to be genuine and perhaps of significance with regard to the way in which the number of visual areas has increased during evolution.

Hierarchical Relationships in Other Regions and in Other Species

The visual cortex has extensive connections with a variety of nonvisual areas, both cortical and subcortical. It is naturally of interest to know the levels at which communication takes place between different functional modalities and whether these other systems are themselves hierarchically organized.

Four nonvisual areas, chosen because they can be directly linked to the visual hierarchy in an orderly fashion, are shown by the noncolored boxes in Figure 4. One of these is somatosensory area 7b, which is connected to areas MSTd and MSTp (Andersen et al., 1990) in a way that places it at the eighth hierarchical level. This allows us to link the visual hierarchy with a somatosensory hierarchy that will be discussed below.

The 3 remaining entries shown in Figure 4 [area 36, the entorhinal cortex (ER), and the hippocampal complex (HC)] are all associated with the limbic system. Area 36 (TG, or temporal polar cortex) is a strip of polysensory neocortex that adjoins entorhinal cortex, area TF, and AITv. It can be placed at the same level as TF because it receives lateral projections from TF and area 46 as well as ascending projections from 7a and perhaps also AIT (Van Hoesen and Pandya, 1975; Goldman-Rakic et al., 1984; Seltzer and Pandya, 1984). The analysis is less straightforward for entorhinal cortex, a complex of several small areas (Amaral et al., 1987) all having a transitional architecture that lacks the cell-dense layer 4 characteristic of most neocortical areas. Entorhinal cortex receives neocortical inputs preferentially from the superficial layers of areas STPp, STPa, TF, TH, 46, and 36 (Amaral et al., 1983; Insausti et al., 1987). This suggests that entorhinal cortex is at a higher level than all of the neocortical areas with which it is connected. The fact that the inputs from these neocortical areas terminate in superficial layers of ER (Van Hoesen and Pandya, 1975) appears, at first glance, to argue against this assignment. However, we presume that the superficial terminations may be related to the absence of a standard granular layer 4 in ER. This interpretation fits well with the fact that the projections from the olfactory bulb, which clearly represent ascending sensory inputs, also terminate in superficial layers in both the pyriform cortex and the olfactory portion of entorhinal cortex (Turner et al., 1978; see also Swanson et al., 1987).

At the top of the hierarchy, we have placed the hippocampal complex, an archicortical region that

includes the dentate gyrus, fields CA1 and CA3, and the subiculum, parasubiculum, and presubiculum. The architecture and connectivity of the hippocampal complex is radically different from the neocortical areas discussed above (cf. Swanson et al., 1987). Hence, it should not be surprising that a modified set of criteria would be necessary for making any hierarchical assignments. Our assignment is based on the fact that the projection from entorhinal cortex arises predominantly from superficial layers, at least in the rat (cf. Swanson et al., 1987), and terminates strongly in the dentate gyrus (Van Hoesen and Pandya, 1975), which, despite its different topology, is a granular layer analogous to neocortical layer 4. Also, the reciprocal projection from CA1 terminates mainly in deep layers of entorhinal cortex (Saunders and Rosene, 1988), and hence is complementary to the neocortical inputs that terminate mainly in superficial layers. Thus, the hippocampal complex is arguably at a higher level than neocortical and transitional cortical areas. We reiterate, however, that this illustration is deceptive in one sense, because the hippocampus and entorhinal complex are by no means the only high-level targets of visual information flow (see below).

Somatosensory and Motor Cortex

The notion that forward and feedback connections can be used to delineate hierarchical relationships is nearly as old for the somatosensory cortex as it is for the visual cortex. The first hierarchical scheme proposed for the somatosensory cortex involved 4 stages of processing among 5 somatosensory areas (Friedman, 1983). More recent studies have extended this hierarchical analysis to include more areas and connections, including several motor areas (Friedman et al., 1986; Neal et al., 1987). As in the visual system, the number of areas and pathways has become so large that it is difficult to analyze all of the critical relationships without having an organized database for the relevant circuitry. Because of our interest in understanding the detailed hierarchical relationships among different modalities, we have extended our analysis to include the 62 known connections among 13 areas of the somatosensory and motor cortices. The laminar information pertaining to these pathways is contained in Table 8, whose format is identical to that of Table 5.

As in the visual system, reciprocity of connections between areas appears to be a general rule, but there are several possible exceptions, including pathways from 7b to 1, SII to 4, and granular insular (Ig) to dysgranular insular (Id) that apparently lack connections in the reverse direction. The great majority of pathways fit cleanly into ascending, descending, and lateral connections according to the same criteria used for the visual cortex. However, by this point, it should not be surprising to find that there are a few irregularities that must be addressed. For example, the projection from SII to 7b appears to terminate in a mixed C/F (columnar/forward) pattern (Friedman et al., 1986), and there are conflicting reports on the ter-

Table 8
Connectivity table for sensorimotor areas

Outputs					Inputs						Hierarchical relationship	Levels crossed
From	To	Origin (S, B, I)	Termination (F, C, M)	Direction (A, L, D)	From	To	Origin (S, B, I)	Termination (F, C, M)	Direction (A, L, D)			
3a	1				1	3a		M	D		1	
3a	2	S	F	A	2	3a		M?	D?	A-D?	2	
3a	SII	S		A	SII	3a		M	D	A-D	5	
3b	1		F	A	1	3b		M	D	A-D	1	
3b	2	S	F	A	2	3b		M(S)	D	A-D	2	
3b	SII	S	F	A	SII	3b		M	D	A-D	5	
1	2	S/B	F	A	2	1		M(S)	D?	A-D?	1	
1	5			u	5	1		M	D		2	
1	SII	S	F	S	SII	1		M	D	A-D	4	
1	7b		F	S	7b	1				NR	5	
2	5		F	A	5	2	S		A	NC	1	
2	7b		F	A	7b	2	S(3, 4)		A?	NC?	4	
2	SII	S		A	SII	2		M	D	A-D	3	
2	4		F	A	4	2	I/S?		?		5	
2	SMA		F	A	SMA	2					6	
5	Ri				Ri	5	I	M	D		1	
5	7b	S	F	A	7b	5	I	M	D	A-D	3	
5	4	B	F		4	5	S?			NC	4	
5	SMA		F	A	SMA	5		(M)	D?	A-D?	5	
5	SII				SII	5			u		2	
5	6	B			6	5					5	
Ri	7b	S	F	A	7b	Ri		M	D	A-D	2	
Ri	SII	S	F	A	SII	Ri		M	D	A-D	1	
Ri	Ig	S	F	A	Ig	Ri		M	D	A-D	3	
SII	7b	S	C/F	A	7b	SII	S	M/F	?	NC	1	
SII	Ig	S	F	A	Ig	SII		M(1)	D	A-D	2	
SII	Id	B	F	A	Id	SII	B	M	D	A-D	3	
SII	4		F?(3)	A?	4	SII			u	NR?	2	
SII	6		F?(3)	A?	6	SII					3	
7b	Ig		F	A	Ig	7b	I		D	A-D	1	
7b	6	B	F	A	6	7b		M		A-D	2	
7b	4	B/I		D?	4	7b					1	
Ig	Id				Id	Ig		M/C		NR	1	
4	SMA	S/B	F(3)/C?	A/L?	SMA	4	B/S	M/C?	D/L?	A-D?	1	
4	6	S/B	F(3)/C?	A/L?	6	4	B	M/C?	D/L?	A-D?	1	
6	SMA		C?	L?	SMA	6		C?	L?	L-L?	0	
Id	35		F?	A?	35	Id	I		D	A-D?	1	
Id	36				36	Id	B				1	

This table shows connections among somatosensory and motor areas in the macaque. Format and symbols are identical to those used in Table 5.

* Reference key:

AAES, '90

F, '83

FJB, '80

Andersen, Asanuma, Essick, and Seigel, 1990

Friedman, 1983

Friedman, Jones, and Burton, 1980

FMOM, '86

GLKR, '84

J, '84

Friedman, Murray, O'Neill, and Mishkin, 1986

Godschalk, Lemon, Kuypers, and Ronday, 1984

Jürgens, 1984 (squirrel monkey)

Table 8
Continued

13 Output References*	14	15	16 Input References*	17	18
Origin	Termination	Special (E, R, S, A)	Origin	Termination	Special (E, R, S, A)
PK, '86 FMOM, '86	JCH, '78			PK, '86 PK, '86 FMOM, '86	
PK, '86 FMOM, '86	JCH, '78 JCH, '78 FJB, '80			VP, '78; PK, '86 PK, '86 FMOM, '86	
PK, '86 FMOM, '86	PK, '86 FJB, '80 PK, '86	E: PK, '86		PK, '86 PK, '86 FMOM, '86	A: FMOM, '86
FMOM, '86	PK, '86 PK, '86 JCH, '78 JCH, '78		PK, '86 PK, '86 PK, '86	FMOM, '86	A: FMOM, '86
NPP, '87 GLKR, '84	NPP, '87 JCH, '78; K, '78; PK, '86 JCH, '78		NPP, '87 NPP, '87 PK, '86	FMOM, '86 NPP, '87; AAES, '90 J, '84(SqM)	A: JCH, '78; E: PK, '86
GLKR, '84					
NPP, '87 FMOM, '86 FMOM, '86 NPP, '87 FMOM, '86 FMOM, '86	F, '83; FMOM, '86 FMOM, '86 FMOM, '86 F, '83; FMOM, '86 F, '83; FMOM, '86 FMOM, '86 FMOM, '86	A: FJB, '80	FMOM, '86 FMOM, '86	NPP, '87 F, '83; FMOM, '86 FMOM, '86 FMOM, '86; NPP, '87 FMOM, '86 FMOM, '86	E: FJB, '80
GLKR, '84 GLKR, '84	NPP, '87 FMOM, '86; AAES, '90	A: FMOM, '86	NPP, '87	K, '78 FMOM, '86	
PS, '85 GLKR, '84; PS, '85	JCH, '78; MCGR, '86; PS, '85 PS, '85 MCGR, '86 K, '78; MCGR, '86 FMOM, '86		MS, '79; GLKR, '84 GLKR, '84; MCGR, '86 FMOM, '86 FMOM, '86	J, '84(SqM); PS, '85 PS, '85 MCGR, '86 J, '84(SqM)	
JCH, '78 K, '78 MCGR, '86 MS, '79	Jones, Coulter, and Hendry, 1978 Künzle, 1978 Matelli, Camarda, Glickstein, and Rizzolatti, 1986 Muakkassa and Strick, 1979		NPP, '87 PK, '86 PS, '85 VP, '78	Neal, Pearson, and Powell, 1987 Pons and Kaas, 1986 Primrose and Strick, 1985 Vogt and Pandya, 1978	

ysis showed the same basic types of laminar patterns found in the visual and somatosensory systems, including S, B, and I patterns for cells of origin. With anterograde labeling, they found that the feedback-type pattern was generally strongest in layer 1, but otherwise conformed to the F, C, and M description that we have used. They reported that rostral-to-caudal projections tended to be of the descending pattern, and that caudal-to-rostral projections tended to be ascending in some cases but columnar in others. In the mediolateral direction, their description suggests that each of the belt areas is at a higher level than the corresponding core area. However, the relationship described for the root areas is incompatible with an internally consistent hierarchy: The root areas show a descending projection to both belt and core areas, but the reciprocal projection from belt and core to the root areas are described as columnar. Clearly, this issue merits further investigation, in order to ascertain whether these constitute unequivocal conflicts with an orderly hierarchy of auditory areas. One small piece of evidence in further support of an auditory hierarchy comes from a single tracer injection in the postauditory area (Pa), which demonstrated descending projections to A1 and ascending connections to a different auditory area (Friedman et al., 1986).

It is also important to have more information on the linkage between auditory and visual systems. It is known that there are auditory projections to the polysensory, but predominantly visual-association area STP (Galaburda and Pandya, 1983; Seltzer and Pandya, 1989b), but there is insufficient information about the laminar patterns to ascertain specific hierarchical relationships.

Other Cortical Regions

The remaining regions of the neocortex yet to be incorporated into our analysis include much of the frontal lobe (orbitofrontal, lateral prefrontal, dorsal prefrontal, and medial prefrontal), as well as cingulate, retrosplenial, and insular regions. Many of these regions have strong interconnections with areas near the top of the visual hierarchy, including areas 46 and 7a, and with somatosensory areas, as well (Selemon and Goldman-Rakic, 1988; Barbas and Pandya, 1989; Cavada and Goldman-Rakic, 1989b). However, there is not a great deal of information about the specific laminar patterns for pathways to and from precisely defined areas in these regions. One striking finding is that large paired injections centered in areas 7a and 46 led to interdigitating columnar patterns of terminations in some regions (e.g., cingulate cortex and orbitofrontal cortex), even though the same injections contributed to complementary (ascending and descending) patterns in other regions, such as the STS (Selemon and Goldman-Rakic, 1988). If this observation is confirmed using small tracer injections clearly confined to single cortical areas, it would indicate a clear breakdown in hierarchical relationships. Thus, there is a strong possibility that substan-

tial portions of frontal and cingulate cortex lie outside the hierarchical framework proposed here for sensory and motor areas. In this regard, it is of interest that the incidence of irregularities in the current visual hierarchy (red lines in Fig. 4) seems to increase at progressively higher levels, suggesting a gradual rather than abrupt breakdown. However, this trend may instead simply represent the greater uncertainty and ambiguity about many of the high-level assignments.

The olfactory system is the last of the sensory modalities for which laminar information about some of the major connections is available. In the macaque, there are several paleocortical and transitional cortical areas associated with olfaction (pyriform cortex, periamygdaloid cortex, and the olfactory portion of the entorhinal cortex). Each of these regions receives direct inputs from the olfactory bulb that, as already noted, terminate preferentially in superficial layers of cortex (Turner et al., 1978). The reciprocal projection from ER terminates in the deeper layers of the pyriform cortex, at least in the rat (cf. Haberly, 1985). Thus, using a different set of criteria for forward and feedback directions, it should be possible to determine whether an orderly anatomical hierarchy can be identified in the olfactory system.

Subcortical Projections

All visual areas that have been appropriately examined have extensive connections with a variety of subcortical structures. Indeed, it would not be surprising if the sheer number of corticosubcortical pathways exceeds that of the corticocortical pathways analyzed in this article. These include linkages with nuclei in the forebrain (amygdala, claustrum, caudate nucleus), thalamus (pulvinar, reticular nucleus), midbrain (superior colliculus), brain stem (pons), hypothalamus, and basal forebrain, to name just some of the prominent structures (cf. Tigges and Tigges, 1985; Yeterian and Pandya, 1985; Andersen, 1987; Iwai and Yukie, 1987; Kaas and Huerta, 1988). In many cases, the connections are strongly reciprocal in nature, just as is characteristic of corticocortical pathways.

The pulvinar complex is physically the largest visually related nucleus and the most interesting to consider with respect to possible hierarchical relationships. The projections from cortex to different pulvinar subdivisions originate predominantly from layer 5, and the reciprocal projections from the pulvinar terminate most heavily in layers 4 and 3 of the extrastriate cortex (Lund et al., 1975; Benevento and Rezak, 1976; Ogren and Hendrickson, 1977). This would be consistent with the pulvinar lying near the bottom of the hierarchy and providing ascending projections to the extrastriate cortex. Interestingly, however, the pulvinar projection to V1 terminates mainly in superficial layers, even though the reciprocal pathway originates from layer 5, just as for extrastriate areas (Rezak and Benevento, 1979). Thus, there is no clear basis for placing the pulvinar in a specific hierarchical relationship relative to V1. The claustrum, on the other hand, projects to layer 4 of V1 and receives inputs

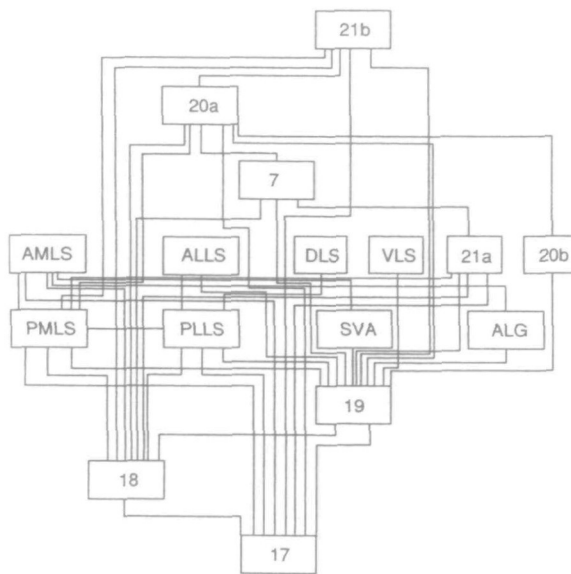

Figure 8. Hierarchy of visual cortical areas in cat, based on connections and laminar patterns reported by Symonds and Rosenquist (1984a,b). Sixteen cortical areas have been arranged into 8 hierarchical levels. Interestingly, the fourth and fifth levels each contain many areas, whereas all other levels contain only single entries. *ALG*, anterolateral gyrus area; *ALLS*, anterolateral lateral suprasylvian; *AMLS*, anteromedial lateral suprasylvian; *DLS*, dorsolateral suprasylvian; *PLLS*, posterolateral lateral suprasylvian; *PMLS*, posteromedial lateral suprasylvian; *SVA*, splenial visual area; *VLS*, ventrolateral suprasylvian.

from layer 6, at least in the cat (LeVay and Sherk, 1981) and thus is arguably at a lower level than any of the cortical areas.

The amygdala receives inputs from mainly superficial layers of areas in the inferotemporal complex and STP, whereas its inputs from TF and TH are mainly from infragranular layers (Aggleton et al., 1980). This is consistent with the amygdala being at a well-defined level just below TF and TH. Information on the anterograde terminations from the amygdala to specific cortical areas would be particularly useful for testing this possibility more precisely, by ascertaining whether there is an ascending (F) pattern to TF and TH and a descending (M) pattern to the other targets.

Other Species

Although the macaque has been the most thoroughly studied, there is also a considerable body of information about laminar connectivity patterns in other species. Among other primates, the owl monkey, squirrel monkey, and bushbaby all show striking similarities with the macaque in the layout and internal organization of the visual cortex, and there are clear homologies among V1, V2, MT (cf. Kaas, 1988), and perhaps many more areas (Sereno and Allman, 1991). In these species, pathways between visual areas are in general reciprocal, with asymmetries in laminar patterns similar to that in the macaque (Tigges et al., 1973, 1981; Weller and Kaas, 1987; Kaas, 1988). Thus, it seems likely that similar principles of hierarchical organization apply throughout the primate order, but this hypothesis clearly merits closer scrutiny.

Among nonprimates, the cat and the rat have been

most closely studied. In the cat, 18 visual areas have been identified (Rosenquist, 1985), and connections between areas are generally reciprocal (Symonds and Rosenquist, 1984a; Sherk, 1986), just as in primates. The laminar distributions for individual pathways generally fit to 1 of the 3 categories we have used, namely, S, B, or I for cells of origin and F, M, or C for terminations (Gilbert and Kelly, 1975; Bullier et al., 1984; Symonds and Rosenquist, 1984a,b; Sherk, 1986). Laminar patterns for pathway terminations have not been studied as extensively as for the cells of origin, but the illustrations provided in Symonds and Rosenquist (1984a) suggest that the anterograde and retrograde labeling patterns are typically consistent with our scheme for ascending and descending pathways (Fig. 3). Moreover, when hierarchical assignments can be made independently for each direction of a reciprocal pair, the patterns are in general complementary. On the other hand, it has been explicitly suggested that connectivity patterns in the cat are not consistent with an anatomical hierarchy (Symonds and Rosenquist, 1984b; Rosenquist, 1985). This argument is based mainly on the occurrence of a bilaminar origin for pathways that would otherwise be constrained to be ascending, as in the specific case of area 19 projecting to area 21a. However, we have already discussed the need in the primate cortex to treat bilaminar retrograde labeling patterns as completely ambiguous with regard to hierarchical assignments.

By applying our revised criteria to connectivity patterns described in Symonds and Rosenquist (1984a,b) for visual cortex in the cat, we have constructed an orderly hierarchy that involves 62 connections among 16 areas organized into 8 levels (Fig. 8). In particular, areas 17, 18, and 19 are located at the first, second, and third stages, respectively. Thus, each occupies a different level despite the fact that they all receive major, direct inputs from the LGN (cf. Stone et al., 1979). This serves to reinforce a point already made in relation to the macaque, namely, that major pathways often traverse more than 1 hierarchical level. They are followed by 2 levels, each containing numerous entries (areas PLLS, PMLS, SVA, and ALG at the fourth level and areas AMLS, ALLS, DLS, VLS, 21a, and 20b at the fifth level). Finally, the top 3 levels revert to the pattern of containing only single entries (area 7 at the sixth level, area 20a at the seventh level, and area 21b at the eighth level). There are a few apparent inconsistencies with this scheme, however. Specifically, using retrograde tracers, the connections between PMLS and PLLS are reported to have an infragranular labeling pattern in both directions, and the projection from VLS to area 19 has a predominantly supragranular origin, even though it is constrained to be higher by its other connections. These laminar assignments were based on relatively small numbers of retrogradely labeled cells, however. With anterograde tracers, the projections from area 21a and area 19 appear not to terminate in a feedback pattern in area 18 despite their being constrained to be at a higher level. Overall, we infer that the cat may have a similar pattern of hierarchical organization as in the

macaque, as well as a similar incidence of irregularities whose biological significance remains to be determined. As in the macaque, however, this scheme is provisional in many respects and is likely to be subject to various revisions. Other recent reports have used different partitioning schemes for distinguishing visual areas, especially in the suprasylvian sulcus (e.g., Sherk, 1986), and much remains to be determined about the connectivity of many of these areas.

In the rat, a recent study by Coogan and Burkhalter (1990) has revealed consistent asymmetries in anterograde labeling patterns between visual areas, in a manner strongly analogous to the hierarchical relations we have described for primates. These findings differ from an earlier report by Miller and Vogt (1984); the difference may be attributed to the greater sensitivity and resolution of the tracer used by Coogan and Burkhalter (1990). The available evidence suggests that there are at least 3 hierarchical levels involving 5 visual areas in the rat. There are several additional visual areas in the rat (Olavarria and Montero, 1984, 1989) whose connectivities have yet to be explored in detail, so it may be that further analysis will reveal evidence for additional hierarchical stages.

In summary, a strategy based on laminar connectivity patterns, particularly in the anterograde direction, provides a rational and objective basis for systematically assessing hierarchical relationships throughout the mammalian neocortex. With appropriate refinements in the criteria for distinguishing forward and feedback connections, we have shown that this hierarchy encompasses the full extent of primate visual and somatosensory-motor cortex. However, much remains to be done in order to resolve the modest number of apparent discrepancies and to ascertain just how generally this hypothesis applies across systems and species.

Intertwined Processing Streams in the Visual Cortex

One of the striking features of the visual hierarchy is the extensive degree of parallel processing, as manifested by the presence of many areas at each level in the middle portion of the hierarchy (6 areas at level 5, 7 areas at level 7, and 5 areas at level 8 in Fig. 4). This contrasts sharply with the presence of only 1 or 2 areas at most levels in the somatosensory-motor hierarchy (Fig. 4 vs. Fig. 7).

The notion of parallel processing streams in the visual system has received considerable attention during the past decade and is the topic of several recent reviews (e.g., Livingstone and Hubel, 1987b; Maunsell and Newsome, 1987; DeYoe and Van Essen, 1988; Lennie et al., 1990). However, the highly distributed connectivity that we have analyzed in the present study raises questions that merit additional discussion. The central issue we wish to address in the remainder of this article is the relationship between the low-level M and P streams that originate in the retina and the high-level streams associated with areas in the temporal and parietal lobes (Ungerleider and Mishkin, 1982; Desimone and Ungerleider, 1989).

If one considers only the most robust anatomical pathways, there is striking evidence for segregated streams over many hierarchical stages (Livingstone and Hubel, 1984a,b, 1987a; DeYoe and Van Essen, 1988; Zeki and Shipp, 1989; Van Essen et al., 1991). This is reflected in the color coding of areas in Figure 4. In brief, the M stream, indicated in shades of red, includes the M layers of the LGN, layer 4B (and also layer 4C α) of V1, the cytochrome oxidase (CO)-enriched thick stripes of V2, and areas V3, MT, MST, and probably also areas V4t and V3A. The M stream provides a notably heavy input into areas of the parietal lobe, which are indicated in orange. The P stream originates from P neurons in the retina and LGN (purple), which then splits into 2 distinct streams that are relayed through layers 4C β and 4A of V1. They are represented in the superficial layers of V1 by the so-called blob and interblob regions revealed by CO histochemistry. The blobs and interblobs project, respectively, to the thin stripes and interstripes of V2; these 2 compartments, in turn, have segregated projections to V4. Both the P-B (blob-associated) stream, shown in shades of violet and the P-I (interblob-associated) stream shown in shades of blue project heavily (by way of V4) to areas in inferotemporal cortex, which are indicated in shades of green.

Superimposed on this skeletal framework are numerous additional pathways, many of which suggest extensive cross talk at different stages of processing, beginning even within V1. Some of this cross talk appears to be mediated by intrinsic circuitry within a single area. Malpeli et al. (1981) used reversible inactivation of specific LGN layers to show that about 1/2 of the cells in V1 can be activated independently through either the M or the P pathway. Anatomical substrates that might underlie this cross talk include dendritic arbors that traverse more than 1 geniculate afferent termination zone in layer 4C, robust projections from P-dominated layer 4C β to M-dominated layer 4C α , and projections from the M-dominated layer 4B to the P-dominated superficial layers of V1 (Fitzpatrick et al., 1985; Lund, 1987, 1988). In V1, the intrinsic connections of blobs and interblobs are highly specific to regions of the same type (Livingstone and Hubel, 1984b), but in V2, there appears to be a greater degree of cross talk in the intrinsic connections of different stripes (Livingstone and Hubel, 1984a; Rockland, 1985).

A second form of cross talk occurs in the ascending connections between areas. At intermediate levels of the hierarchy, areas MT, V3, V3A, and V4t all are dominated by M inputs (from the thick stripes of V2 in all cases, plus layer 4B of V1 for MT and V3). However, several of these areas receive substantial input from other stripe compartments of V2. In particular, projections to MT occasionally arise from thin stripes as well as thick stripes (DeYoe and Van Essen, 1985; Shipp and Zeki, 1989). Also, the projections to V3, V3A, and V4t arise from more than 1 stripe compartment in V2 (Felleman et al., 1988). Area V4 is dominated by P inputs in terms of the direct projections from V2 thin stripes and interstripes, yet it also re-

ceives major projections from each of the aforementioned M-dominated areas V3, MT, V3A, and V4t.

A comparable degree of cross talk persists in the ascending projections leading to the parietal and inferotemporal lobes. V4 projects most strongly to inferotemporal areas, but it also has substantial projections to parietal cortex, directly to VIP and LIP and indirectly through DP, MST, MSTl, and MT. Likewise, MT projects heavily to the parietal cortex (directly to VIP and indirectly via MSTd and MSTl), but it also has indirect connections with inferotemporal areas via FST and V4. There are also direct connections between parietal and inferotemporal areas (LIP-PITv and 7a-AITd), as well as indirect linkages by way of FST, STP, and frontal lobe areas.

A third mode for interaction between streams is by way of feedback pathways. For example, there is evidence that feedback from areas V4 and MT may include multiple stripe compartments in V2, suggesting greater cross talk in the descending than in the ascending direction (Zeki and Shipp, 1988, 1989; Shipp and Zeki, 1989). On the other hand, we have seen cases in which the feedback from V3 and V4 to V2 is more restricted than the reciprocal ascending pathway (D. J. Felleman and D. C. Van Essen, unpublished observations). The overall issue of cross talk in feedback pathways clearly deserves further investigation.

Taken as a whole, this anatomical description does not support a rigid segregation of pathways all the way from the magnocellular/parvocellular dichotomy at the low end to the parietal/temporal dichotomy at the high end. It remains to be seen to what degree the divergence and convergence that we have discussed at the level of areas and compartments as a whole persists when one examines the inputs and outputs of single cells.

Single Neuron Connectivity

Thus far, we have concentrated on the connections of entire areas or of layers and compartments within areas, without addressing the issue of heterogeneity among the individual neurons that make up a layer or an area. Presumably, any given neuron, for example, in V4, projects to far fewer areas than the total of 39 areas with which V4 is reported to be linked. In the extreme, any single neuron might project, at most, to 1 other cortical target area. Most of what we know about this issue comes from a relatively small number of double-retrograde-labeling studies in cats and monkeys, in which tracers are injected into topographically corresponding portions of 2 different areas (cf. Kennedy and Bullier, 1985; Bullier and Kennedy, 1987). In general, this approach reveals a significant number of doubly labeled cells, signifying that individual neurons can indeed have collaterals projecting to more than 1 area. Although the percentage of doubly labeled cells is relatively modest (e.g., less than 10% of the labeled cells in the study by Perkel et al., 1986), the interpretation of this number must take into account the likelihood that many, if not most, singly labeled neurons had collaterals that went to different areas that had not received a

tracer injection. The average number of target areas per cortically projecting neuron could plausibly be well under or well over 2. In the cat, there is evidence that this number is greater for descending pathways than for ascending pathways, and that some cells can even contribute simultaneously to both directions, by making both an ascending and a descending connection (Bullier et al., 1984; Bullier and Kennedy, 1987).

Functional Implications

We have concentrated in this study primarily on an anatomical analysis that suggests 5 key principles of primate cortical organization: (1) a large number of visual areas, (2) highly distributed connectivity among areas, (3) reciprocity of connections, (4) hierarchical organization, and (5) distinct, yet intertwined, processing streams. We now comment on what these principles might signify for understanding the functions of different visual areas.

Distributed Hierarchical Processing

The hierarchical scheme for visual cortex that we have presented is grounded explicitly on anatomical criteria. Whether each level of the hierarchy represents a distinct stage of information processing is a separate issue that must be addressed mainly by physiological and behavioral approaches. One type of physiological evidence in support of the hierarchy comes from comparisons of receptive field size, as conventionally plotted using moving bars or edges (the "classical" receptive field). In V1, receptive fields are typically very small, and they increase progressively at successive stages of the hierarchy, ultimately approaching the entire visual field in extent in some of the inferotemporal and parietal areas (cf. Van Essen, 1985, for references). Ideally, one would like to know whether these increases occur in stepwise fashion at each hierarchical stage. However, such information is not readily attainable, given that several factors contribute to differences in receptive field size, including a strong dependence on eccentricity, plus effects of anesthesia and of interanimal variability.

Another important physiological measure concerns the occurrence of emergent receptive field properties at progressively higher levels of the hierarchy. For example, area V1 clearly represents a more advanced stage of processing than the LGN by virtue of the emergence or sharpening of selectivity for stimulus orientation, spatial frequency, length, direction, and binocular disparity (cf. Hubel and Wiesel, 1968; Schiller et al., 1976a-c; Poggio and Fischer, 1977; DeValois et al., 1982). Until recently, however, there were few examples of this type to distinguish different extrastriate areas from one another or even from V1. That situation is now changing, and a few of the more notable examples are worth explicit mention: (1) Many cells in V2, but not in V1, are responsive to patterns that elicit percepts of subjective contours in human observers (Peterhans and von der Heydt, 1989; von der Heydt and Peterhans, 1989). (2) Some cells in MT, but not in V1, are selective for the motion of a complex pattern rather than the individual oriented

components (Movshon et al., 1986). (3) Some cells in the inferotemporal cortex are selective for faces or other complex patterns (Desimone et al., 1984; Baylis et al., 1987; Perrett et al., 1987; Saito et al., 1987). These and other examples support the notion that higher stages of the cortical hierarchy represent more advanced levels of processing. Much more evidence is needed to test the generality of this hypothesis, however.

The physiological properties discussed thus far (increases in classical receptive field size and more advanced receptive field selectivities) may largely reflect the contributions of ascending pathways and of circuitry intrinsic to each area. The massive descending pathways that are so prominent anatomically may subserve a different set of functions. One likely possibility is that descending connections contribute to a set of modulatory surround influences, in which stimuli well outside the classical receptive field can dramatically influence the responses to stimuli within the receptive field. Such modulatory effects have now been demonstrated in the analysis of motion (Allman et al., 1985; Saito et al., 1986), color (Zeki, 1983), form (Desimone and Schein, 1987), and texture (Van Essen et al., 1989). Another perspective is that descending pathways may contribute to the modulation of response properties by visual attention in area V4 (Moran and Desimone, 1985) and more generally, for dynamic control of the routing of information through each visual area (Anderson and Van Essen, 1987; Van Essen and Anderson, 1990). However, there is no strong basis at present for assigning any of these interactions to a strictly corticocortical system as distinct from pathways involving the pulvinar or other subcortical structures. Finally, descending pathways may play a critical role in memory processes (including their formation, consolidation, and/or readout) at higher cortical levels, particularly in the temporal lobe.

These examples illustrate how the existence of feedback pathways can remain consistent with the notion of hierarchical processing in the broad sense, even though they rule out a strictly serial scheme. The physiological properties of any given cortical neuron will, in general, reflect many descending as well as ascending influences. Nevertheless, the cell may represent a well-defined hierarchical position in terms of the types of information it represents explicitly and the way in which that information is used.

Functionality of Processing Streams

Why should the visual system contain processing streams that, in some respects, remain distinct through many successive stages of the hierarchy, yet show significant anatomical cross talk at many (perhaps all) stages? To address this question, it is useful to consider the way in which visual information is encoded at each hierarchical stage and how this information may be used for perception and visually guided behavior.

Physiological distinctions between processing streams are evident from the outset, in that M and P channels differ markedly in how they represent in-

formation along spatial, temporal, and spectral dimensions (cf. Shapley and Perry, 1986; Lennie et al., 1990). At any given eccentricity, P cells, on average, have smaller receptive fields and higher spatial resolution, whereas M cells have higher temporal resolution, higher contrast sensitivity, and a lower absolute threshold. P cells tend to give sustained responses, whereas M cells respond only transiently. P cells also have spectrally opponent receptive fields, whereas M cells carry only a nonlinear representation of spectral contrast. These differences suggest an overall strategy in which the M and P channels handle distinct, but partially overlapping, portions of an information space that includes the dimensions of space, time, and spectral composition (Van Essen and Anderson, 1990).

In the visual cortex, each processing stream maintains a distinct profile of receptive field characteristics (for reviews, see DeYoe and Van Essen, 1988; Livingstone and Hubel, 1988). Most notably, the P-B stream contains a high incidence of cells that are wavelength selective, suggesting that it is particularly involved in color perception. The M stream contains a high incidence of cells selective for direction of motion and for binocular disparity, suggesting that it is heavily involved in the analysis of motion and depth. The P-I stream contains a high incidence of orientation-selective cells, suggesting that it is involved in pattern and form recognition. However, selectivity for these low-level stimulus parameters is, in general, distributed across more than 1 processing stream. For example, wavelength selectivity is common among neurons in the P-I stream as well as the P-B stream; orientation selectivity and disparity selectivity are common in both the P-I stream and the M stream. This physiological description is consistent with the anatomical picture of streams that are distinct, yet closely interlinked by cross talk at many levels.

Two types of reasoning support the notion that such cross talk and intermixing of information may reflect sensible design principles for the visual system. They can best be illustrated in relation to a specific example, such as the way in which we analyze an object that is moving across the visual field. First, consider what sources of information are useful for signaling object motion. If the object is moving rapidly, it will elicit responses mainly in M cells, because of their sensitivity to transient changes. However, if the object is moving very slowly, or if it is defined mainly by a high spatial frequency pattern, the evoked activity may be carried mainly by P cells. Hence, in order to have a motion-analyzing system that operates efficiently over a wide range of velocities, it would make sense to draw information primarily from the M channel, with the P channel playing an important, but subsidiary, role. There is now direct physiological evidence in support of this hypothesis (Maunsell et al., 1990).

Once motion information has been extracted, there are several distinct ways in which it can be used. The most obvious is for computing the trajectory in which the object is headed. In addition, velocity information contributes to our perception of depth (by way of

motion parallax), shape (by way of structure from motion), and texture (by way of dynamic reflectance changes, as in a rippling surface). Consequently, it may be important for this information to be distributed both to parietal areas and to inferotemporal areas in order to mediate different aspects of perception.

For both form and distance perception, a stronger case can be made for a major role of both channels. The cues for shape and for depth arise from a wide range of spatial frequencies; moreover, form and distance perception are robust for static images, where the P channel presumably dominates, and for moving or transient images, where the M channel presumably dominates. For the P channel to be inoperative in these processes would imply that the high-resolution information conveyed by 90% of LGN neurons is irrelevant to processes that are demonstrably capable of hyperacuity levels of performance. For the M channel to be inoperative in either process would pose a puzzle as to how we do so well at perceiving depth and form at low contrast and also under scotopic conditions, where M cells are much more sensitive than P cells (Purpura et al., 1988). The effects of selectively lesioning the M and P layers of the LGN on specific behavioral tasks provide support for the notion that M and P channels each contribute to multiple aspects of perception (Schiller and Logothetis, 1990; Schiller et al. 1990; Merigan et al., 1991).

In a more general sense, there appears to be a complex, but orderly, relationship between low-level sensory cues (e.g., orientation, velocity, disparity, and spectral composition), high-level aspects of perception (e.g., perception of shape, surface qualities, and spatial relationships), and the processing streams that generate one from the other (DeYoe and Van Essen, 1988). The mapping is not 1:1, because many low-level cues are represented in more than 1 stream, both in the retina and at cortical levels, and because the attributes that we perceive about objects in the world can often be derived from more than 1 sensory cue. The determination of which particular computational strategies are associated with specific pathways, areas, compartments, and processing substreams remains a largely unresolved challenge for the future.

In the somatosensory cortex, there is physiological evidence for parallel channels that are manifested at the first hierarchical level by the partitioning of area 3b into modules dominated, respectively, by rapidly adapting and slowly adapting afferents (Sur et al., 1981) and by the preferential activation of area 3a by muscle spindle afferents (cf. Merzenich et al., 1978; Kaas et al., 1981). This functional segregation may persist at higher levels in terms of the preferential activation of area 1 by transient cutaneous stimulation and area 2 by sustained or deep pressure stimulation (Merzenich et al., 1978; E. Gardner, personal communication). At a still higher level, it has been suggested on the basis of lesion studies as well as connectational data that there may be a ventrally directed pathway, particularly involving SII, Ig, and Id, that is primarily involved in tactile object recognition, and a dorsally directed pathway, particularly involving areas 5 and

7b, that is primarily involved in somatomotor guidance, spatial perception of the body, and other somesthetic spatial functions (Friedman et al., 1986). Clearly, these observations suggest interesting analogies with the different processing streams in vision. Comparisons across these systems may help to clarify the nature of the tasks they must perform and the computational strategies that provide efficient and general solutions within the framework of the stereotyped architecture of the mammalian neocortex.

Notes

1. An accurate physical model of the macaque brain was a valuable adjunct in transferring areal boundaries on to the cortical map. Two such enamel-painted, plaster-coated, styrofoam models were available, one at 3 times life size and the other at a scale of 9-fold. They were based on the outlines of cortical layer 4 in a series of horizontal sections of the right hemisphere of a different brain than that used to generate the cortical map in this figure. Boundaries of individual cortical areas identified in the studies indicated in the text and in Table 1 were marked onto the brain model, mainly on the basis of the relationship to various geographical landmarks. Once the physical model had been marked, the various areal boundaries were transposed to outlines of the sections on which the model was based. The next step was to transpose boundaries to sections of the brain from which the cortical map was made. Although both the model and the map were based on quasi-horizontal sections, they were not precisely coplanar, and there were also modest individual differences in the exact size and configuration of various gyri and sulci. Nonetheless, we were able to determine an orderly mapping from one set of sections to the other and to use this mapping to transpose areal boundaries from one hemisphere to the other. The last step was a straightforward transposition from individual sections to the corresponding contours of the cortical map. The manually generated map, complete with areal boundaries, was optically scanned and used as a template for creating the color map with the CANVAS program on a Macintosh II computer. Boundaries for each area and for major cortical regions were traced over this template to create separate objects that could be independently colored, as in Figure 2, and also analyzed for surface area (see Table 2).

We thank R. Andersen and L. Ungerleider for providing preprints of their work, T. Morales-Oblon for typing, K. Tazumi and S. Kallenbach for assistance, and numerous colleagues for valuable discussions and suggestions. We also thank J. Whitehead and K. Tazumi for the fabrication of the physical brain models that were used for analyzing the location of cortical areas. This work was supported by NIH Grant EY02091 and ONR Grant N00014-89-1192 to D.V.E. and by an Alfred P. Sloan research fellowship and a Whitehall Foundation Grant to D.J.F. Readers interested in acquiring copies of the EXCEL database or of the CANVAS cortical hierarchy should communicate with D.J.F.

Address correspondence to Dr. Van Essen, Division of Biology, 216-76, California Institute of Technology, Pasadena, CA 91125.

References

- Aggleton JP, Burton MJ, Passingham RE (1980) Cortical and subcortical afferents to the amygdala of the rhesus monkey (*Macaca mulatta*). *Brain Res* 190:347-368.
- Allman JM, Miezin F, McGuinness E (1985) Stimulus specific responses from beyond the receptive field: neurophysiological mechanisms for local-global comparisons of visual motion. *Annu Rev Neurosci* 3:532-548.
- Amaral DG, Insausti R, Cowan WM (1983) Evidence for a direct projection from the superior temporal gyrus to the entorhinal cortex in the monkey. *Brain Res* 275:263-277.
- Amaral DG, Insausti R, Cowan WM (1987) The entorhinal

- cortex of the monkey. I. Cytoarchitectonic organization. *J Comp Neurol* 264:326-355.
- Andersen RA (1987) The role of the inferior parietal lobule function in spatial perception and visuo-motor integration. In: *Handbook of physiology. Sec 1, The nervous system, Vol IV, higher functions of the brain, Pt 2* (Plum F, Mountcastle VB, and Geiger SR, eds), pp 438-518. Bethesda, MD: American Physiological Society.
- Andersen RA, Asanuma C, Cowan WM (1985) Callosal and prefrontal associational projecting cell populations in area 7A of the macaque monkey: a study using retrogradely transported fluorescent dyes. *J Comp Neurol* 232:443-455.
- Andersen RA, Asanuma C, Essick G, Siegel RM (1990) Cortico-cortical connections of anatomically and physiologically defined subdivisions within the inferior parietal lobule. *J Comp Neurol* 296:65-113.
- Anderson CH, Van Essen DC (1987) Shifter circuits: a computational strategy for dynamic aspects of visual processing. *Proc Natl Acad Sci USA* 84:6297-6301.
- Barbas H (1986) Pattern in the laminar origin of cortico-cortical connections. *J Comp Neurol* 252:415-422.
- Barbas H (1988) Anatomic organization of basoventral and mediodorsal visual recipient prefrontal regions in the rhesus monkey. *J Comp Neurol* 276:313-342.
- Barbas H, Mesulam M-M (1981) Organization of afferent input to subdivisions of area 8 in the rhesus monkey. *J Comp Neurol* 200:407-431.
- Barbas H, Mesulam M-M (1985) Cortical afferent input to the principalis region of the rhesus monkey. *Neuroscience* 15:619-637.
- Barbas H, Pandya DN (1989) Architecture and intrinsic connections of the prefrontal cortex in the rhesus monkey. *J Comp Neurol* 286:353-375.
- Baylis GC, Rolls ET, Leonard CM (1987) Functional subdivisions of the temporal lobe neocortex. *J Neurosci* 7:330-342.
- Benevento LA, Rezak M (1976) The cortical projections of the inferior pulvinar and adjacent lateral pulvinar in the rhesus monkey (*Macaca mulatta*): an autoradiographic study. *Brain Res* 108:1-24.
- Blasdel GG, Lund JS (1983) Termination of afferent axons in macaque striate cortex. *J Neurosci* 3:1389-1413.
- Blatt GJ, Stoner GR, Anderson RA (1987) The lateral intraparietal area (LIP) in the macaque: associational connections and visual receptive field organization. *Soc Neurosci Abstr* 13:177.13.
- Blatt GJ, Andersen RA, Stoner GR (1990) Visual receptive field organization and cortico-cortical connections of the lateral intraparietal area (area LIP) in the macaque. *J Comp Neurol* 299:421-445.
- Boussaoud D, Ungerleider LC, Desimone R (1990) Pathways for motion analysis: cortical connections of the medial superior temporal and fundus of the superior temporal visual areas in the macaque. *J Comp Neurol* 296:462-495.
- Brady DR (1985) The posterior parahippocampal cortex of the monkey: organization and analysis of major association projections. PhD thesis, University of Iowa.
- Brodmann K (1905) Beitrage zur histologischen Localisation der Grosshirnrinde. Dritte Mitteilung. Die Rindfelder der niederen Affen. *J Psychol Neurol* 4:177-226.
- Bruce C, Goldberg ME (1984) Physiology of the frontal eye fields. *Trends Neurosci* 7:436-441.
- Bruce C, Desimone R, Gross CG (1981) Visual properties of neurons in a polysensory area in superior temporal sulcus of the macaque. *J Neurophysiol* 46:369-384.
- Bruce C, Goldberg ME, Bushnell MC, Stanton GB (1985) Primate frontal eye fields. II. Physiological and anatomical correlates of electrically evoked eye movements. *J Neurophysiol* 54:714-734.
- Bullier J, Kennedy H (1987) Axonal bifurcation in the visual system. *Trends Neurosci* 10:205-210.
- Bullier J, Kennedy H, Salinger W (1984) Branching and laminar origin of projections between visual cortical areas in the cat. *J Comp Neurol* 228:329-341.
- Burkhalter A, Van Essen DC (1983) The connections of the ventral posterior area (VP) in the macaque. *Soc Neurosci Abstr* 9:46.5.
- Burkhalter A, Felleman DJ, Newsome WT, Van Essen DC (1986) Anatomical and physiological asymmetries related to visual areas V3 and VP in macaque extrastriate cortex. *Vision Res* 26:63-80.
- Cavada C, Goldman-Rakic PS (1989a) Posterior parietal cortex in rhesus monkey: I. Parcellation of areas based on distinctive limbic and sensory corticocortical connections. *J Comp Neurol* 287:393-421.
- Cavada C, Goldman-Rakic PS (1989b) Posterior parietal cortex in rhesus monkey: II. Evidence for segregated corticocortical networks linking sensory and limbic areas with the frontal lobe. *J Comp Neurol* 287:422-445.
- Colby CL, Gattass R, Olson CR, Gross CG (1988) Topographic organization of cortical afferents to extrastriate visual area PO in the macaque: a dual tracer study. *J Comp Neurol* 269:392-413.
- Coogan TA, Burkhalter A (1990) Conserved patterns of corticocortical connections define areal hierarchy in rat visual cortex. *Exp Brain Res* 80:49-53.
- Cragg BG (1969) The topography of the afferent projections in the circumstriate visual cortex of the monkey studied by the Nauta method. *Vision Res* 9:733-747.
- Cusick CG, Wall JT, Felleman DJ, Kaas JH (1989) Somatotopic organization of the lateral sulcus in owl monkeys: area 3b, S-II, and a ventral somatosensory area. *J Comp Neurol* 282:169-190.
- Desimone R, Schein SJ (1987) Visual properties of neurons in area V4 of the macaque: sensitivity to stimulus form. *J Neurophysiol* 57:835-868.
- Desimone R, Ungerleider LB (1986) Multiple visual areas in the caudal superior temporal sulcus of the macaque. *J Comp Neurol* 248:164-189.
- Desimone R, Ungerleider LB (1989) Neural mechanisms of visual processing in monkeys. In: *Handbook of neuropsychology, Vol 2* (Boller F and Grafman J, eds), pp 267-299. New York: Elsevier.
- Desimone R, Fleming J, Gross CG (1980) Prestriate afferents to inferior temporal cortex: an HRP study. *Brain Res* 184:41-45.
- Desimone R, Albright TD, Gross CG, Bruce C (1984) Stimulus-selective properties of inferior temporal neurons in the macaque. *J Neurosci* 4:2051-2062.
- DeValois RL, Albrecht DG, Thorell LG (1982) Spatial frequency selectivity of cells in macaque visual cortex. *Vision Res* 22:545-559.
- DeYoe EA, Van Essen DC (1985) Segregation of efferent connections and receptive field properties in visual area V2 of the macaque. *Nature* 317:58-61.
- DeYoe EA, Van Essen DC (1988) Concurrent processing streams in monkey visual cortex. *Trends Neurosci* 11:219-226.
- DeYoe EA, Felleman DJ, Knierim JJ, Olavarria JF, Van Essen DC (1988) Heterogeneous subregions of macaque visual area V4 receive selective projections from V2 thin-stripe and interstripe subregions. *Invest Ophthalmol Vis Sci [Suppl]* 29:115.
- DeYoe EA, Hockfield S, Garren H, Van Essen DC (1990) Antibody labeling of functional subdivisions in visual cortex: CAT-301 immunoreactivity in striate and extrastriate cortex of the macaque monkey. *Vis Neurosci* 5:67-81.
- Felleman DJ, Van Essen DC (1983) The connections of area V4 of macaque monkey extrastriate cortex. *Soc Neurosci Abstr* 9:153.
- Felleman DJ, Van Essen DC (1984) Cortical connections of area V3 in macaque extrastriate cortex. *Soc Neurosci Abstr* 10:933.
- Felleman DJ, DeYoe EA, Van Essen DC (1985) Two topographically organized visual areas in ventral extrastriate cortex of the macaque. *Soc Neurosci Abstr* 11:1246.

- Felleman DJ, Knierim JJ, Van Essen DC (1986) Multiple topographic and non-topographic subdivisions of the temporal lobe revealed by the connections of area V4 in macaques. *Soc Neurosci Abstr* 12:1182.
- Felleman DJ, Burkhalter A, Van Essen DC (1987) Visual area PIP: an extrastriate cortical area in the posterior intraparietal sulcus of macaque monkeys. *Soc Neurosci Abstr* 13:626.
- Felleman DJ, DeYoe EA, Knierim JJ, Olavarria J, Van Essen DC (1988) Compartmental organization of projections from V2 to extrastriate areas V3, V3A, and V4t in macaque monkeys. *Invest Ophthalmol Vis Sci [Suppl]* 29:115.
- Fenstemaker SB (1986) The organization and connections of visual cortical area TEO in the macaque. PhD thesis, Princeton University.
- Fenstemaker SB, Olson CR, Gross CG (1984) Afferent connections of macaque visual areas V4 and TEO. *Invest Ophthalmol Vis Sci* 25:213.
- Fitzpatrick D, Lund JS, Blasdel GG (1985) Intrinsic connections of macaque striate cortex: afferent and efferent connections of lamina 4C. *J Neurosci* 5:3329–3349.
- Friedman DP (1983) Laminar patterns of termination of corticocortical afferents in the somatosensory system. *Brain Res* 273:147–151.
- Friedman DP, Jones EG, Burton H (1980) Representation pattern in the second somatic sensory area of the monkey cerebral cortex. *J Comp Neurol* 192:21–41.
- Friedman DP, Murray EA, O'Neill JB, Mishkin M (1986) Cortical connections of the somatosensory fields of the lateral sulcus of macaques: evidence for a corticocolimbic pathway for touch. *J Comp Neurol* 252:323–347.
- Galaburda AM, Pandya DN (1983) The intrinsic architectonic and connective organization of the superior temporal region in the rhesus monkey. *J Comp Neurol* 221:169–184.
- Gattass R, Gross CG, Sandell JH (1981) Visual topography of V2 in the macaque. *J Comp Neurol* 201:519–539.
- Gattass R, Sousa APB, Gross CG (1988) Visuotopic organization and extent of V3 and V4 of the macaque. *J Neurosci* 8:1831–1845.
- Gilbert CD, Kelly JP (1975) The projections of cells in different layers of the cat's visual cortex. *J Comp Neurol* 163:81–105.
- Godschalk M, Lemon RN, Kuypers HGJM, Rondan HK (1984) Cortical afferents and efferents of monkey postarcuate area: an anatomical and electrophysiological study. *Exp Brain Res* 56:410–424.
- Goldman-Rakic PS (1988) Topography of cognition: parallel distributed networks in primate association cortex. *Annu Rev Neurosci* 11:137–156.
- Goldman-Rakic PS, Selemon LD, Schwartz ML (1984) Dual pathways connecting the dorsolateral prefrontal cortex with the hippocampal formation and parahippocampal cortex in the rhesus monkey. *Neuroscience* 12:719–743.
- Haberly LB (1985) Neuronal circuitry in olfactory cortex: anatomy and functional implications. *Chem Sens* 10:219–238.
- Hendry SCH, Jones EG, Hockfield S, McKay RDG (1988) Neuronal populations stained with the monoclonal antibody Cat-301 in the mammalian cerebral cortex and thalamus. *J Neurosci* 8:518–542.
- Hikosaka K, Iwai E, Saito H-A, Tanaka K (1988) Polysensory properties of neurons in the anterior bank of the caudal superior temporal sulcus of the macaque monkey. *J Neurophysiol* 60:1615–1637.
- Horel JA, Pytko-Joiner DE, Voytko ML, Salisbury K (1987) The performance of visual tasks while segments of the inferotemporal cortex are suppressed by cold. *Behav Brain Res* 23:29–42.
- Hubel DH, Livingstone MS (1987) Segregation of form, color, and stereopsis in primate area 18. *J Neurosci* 7:3378–3415.
- Hubel DH, Wiesel TN (1962) Receptive fields, binocular interaction and functional architecture in the cat's visual cortex. *J Physiol (Lond)* 160:106–154.
- Hubel DH, Wiesel TN (1965) Receptive fields and functional architecture in two non-striate visual areas (18 and 19) of the cat. *J Neurophysiol* 18:229–289.
- Hubel DH, Wiesel TN (1968) Receptive fields and functional architecture of monkey striate cortex. *J Physiol (Lond)* 195:215–243.
- Huerta MF, Krubitzer LA, Kaas JH (1987) Frontal eye field as defined by intracortical microstimulation in squirrel monkeys, owl monkeys, and macaque monkeys. II. Cortical connections. *J Comp Neurol* 265:332–361.
- Hutchins KD, Martino AM, Strick PL (1988) Corticospinal projections from the medial wall of the hemisphere. *Exp Brain Res* 71:667–672.
- Insausti R, Amaral DG, Cowan WM (1987) The entorhinal cortex of the monkey. II. Cortical afferents. *J Comp Neurol* 264:356–395.
- Iwai E (1981) Visual mechanisms in the temporal and prestriate association cortices of the monkey. *Adv Physiol Sci* 17:279–286.
- Iwai E, Yukie M (1987) Amygdalofugal and amygdalopetal connections with modality-specific visual cortical areas in macaques (*Macaca fuscata*, *M. mulatta*, and *M. fascicularis*). *J Comp Neurol* 261:362–387.
- Iwai E, Yukie M (1988) A direct projection from hippocampal field CA1 to ventral area TE of inferotemporal cortex in the monkey. *Brain Res* 444:397–401.
- Iwai E, Yukie M, Suyama H, Shirakawa S (1987) Amygdalar connections with middle and inferior temporal gyri of the monkey. *Neurosci Lett* 83:25–29.
- Jones EG, Burton H (1976) Areal differences in the laminar distribution of thalamic afferents in cortical fields of the insular, parietal and temporal regions of primates. *J Comp Neurol* 168:197–248.
- Jones EG, Coulter JD, Hendry SHC (1978) Intracortical connectivity of architectonic fields in the somatic sensory, motor and parietal cortex of monkeys. *J Comp Neurol* 181:291–348.
- Jürgens U (1984) The efferent and afferent connections of the supplementary motor area. *Brain Res* 300:63–81.
- Kaas JH (1988) Why does the brain have so many visual areas? *J Cogn Neurosci* 1:121–135.
- Kaas JH, Huerta MF (1988) Subcortical visual system of primates. In: *Comparative primitive biology*, Vol 4, Neuroscience (Steklis HP, ed), pp 327–391. New York: Liss.
- Kaas JH, Nelson RJ, Sur M, Merzenich MM (1981) Organization of somatosensory cortex in primates. In: *The organization of the cerebral cortex* (Schmitt FO, Worden FG, Adelman G, and Dennis SG, eds), pp 237–261. Cambridge, MA: MIT Press.
- Kennedy H, Bullier J (1985) A double-labelling investigation of the afferent connectivity to cortical areas V1 and V2 of the macaque monkey. *J Neurosci* 5:2815–2830.
- Komatsu H, Wurtz RH (1988a) Relation of cortical areas MT and MST to pursuit eye movements. I. Localization and visual properties of neurons. *J Neurophysiol* 60:580–603.
- Komatsu H, Wurtz RH (1988b) Relation of cortical areas MT and MST to pursuit eye movements. III. Interaction with full-field visual stimulation. *J Neurophysiol* 60:621–644.
- Komatsu H, Wurtz RH (1989) Modulation of pursuit of eye movements by stimulation of cortical areas MT and MST. *J Neurophysiol* 62:31–47.
- Krubitzer LA, Kaas JH (1990) The organization and connections of somatosensory cortex in marmosets. *J Neurosci* 10:952–974.
- Künzle H (1978) An autoradiographic analysis of the efferent connections from premotor and adjacent prefrontal regions (areas 6 and 9) in *Macaca fascicularis*. *Brain Behav Evol* 15:185–234.
- Künzle H, Akert K (1977) Efferent connections of cortical, area 8 (frontal eye field) in *Macaca fascicularis*. A reinvestigation using the autoradiographic technique. *J Comp Neurol* 173:147–164.
- Leichnetz GR (1980) An intrahemispheric columnar pro-

- jection between two cortical multisensory convergence areas (inferior parietal lobule and prefrontal cortex): an anterograde study in the macaque using HRP gel. *Neurosci Lett* 18:119-124.
- Lennie P (1980) Parallel visual pathways: a review. *Vision Res* 20:561-594.
- Lennie P, Trevarthen C, Van Essen D, Wassle H (1990) Parallel processing of visual information. In: *Visual perception: the neurophysiological foundations* (Spillman L and Werner J, eds), pp 103-128. San Diego: Academic.
- LeVay S, Sherk H (1981) The visual claustrum of the cat. I. Structure and connections. *J Neurosci* 1:956-980.
- Livingstone MS, Hubel DH (1984a) Anatomy of physiology of a color system in the primate visual cortex. *J Neurosci* 4:309-356.
- Livingstone MS, Hubel DH (1984b) Specificity of intrinsic connections in primate primary visual cortex. *J Neurosci* 4:2830-2835.
- Livingstone MS, Hubel DH (1987a) Connections between layer 4B of area 17 and the thick cytochrome oxidase stripes of area 18 in the squirrel monkey. *J Neurosci* 7:3371-3377.
- Livingstone MS, Hubel DH (1987b) Psychophysical evidence for separate channels for the perception of form, color, movement and depth. *J Neurosci* 7:3416-3468.
- Livingstone M, Hubel D (1988) Segregation of form, color, movement, and depth: anatomy, physiology, and perception. *Science* 240:740-749.
- Lund JS (1987) Local circuit neurons of macaque monkey striate cortex: I. Neurons of laminae 4C and 5A. *J Comp Neurol* 257:60-92.
- Lund JS (1988) Excitatory and inhibitory circuitry and laminar mapping strategies in primary visual cortex of the monkey. In: *Signal and sense: local and global order in perceptual maps* (Edelman GM, Gall WE, and Cowan WM, eds). New York: Wiley.
- Lund JS, Lund RD, Hendrickson AE, Bunt AH, Fuchs AF (1975) The origin of efferent pathways from the primary visual cortex, area 17, of the macaque monkey as shown by retrograde transport of horseradish peroxidase. *J Comp Neurol* 164:287-304.
- Macko KA, Mishkin M (1985) Metabolic mapping of higher-order visual areas in the monkey. In: *Brain imaging and brain function* (Sokoloff L, ed), pp 73-86. New York: Raven.
- Maguire WM, Baizer JS (1984) Visuotopic organization of the prelunate gyrus in rhesus monkey. *J Neurosci* 4:1690-1704.
- Malpeli JG, Schiller PH, Colby CL (1981) Response properties of single cells in monkey striate cortex during reversible inactivation of individual lateral geniculate laminae. *J Neurophysiol* 46:1102-1119.
- Mann SE, Thau R, Schiller PH (1988) Conditional task-related responses in monkey dorsomedial frontal cortex. *Exp Brain Res* 69:460-468.
- Matelli M, Camarda R, Glickstein M, Rizzolatti G (1986) Afferent and efferent projections of the inferior area 6 in the macaque monkey. *J Comp Neurol* 251:281-298.
- Maunsell JHR, Newsome WT (1987) Visual processing in monkey extrastriate cortex. *Annu Rev Neurosci* 10:363-402.
- Maunsell JHR, Van Essen DC (1983) The connections of the middle temporal visual area (MT) and their relationship to a cortical hierarchy in the macaque monkey. *J Neurosci* 3:2563-2586.
- Maunsell JHR, Van Essen DC (1987) Topographic organization of the middle temporal visual area in the macaque monkey: representational biases and the relationship to callosal connections and myeloarchitectonic boundaries. *J Comp Neurol* 266:535-555.
- Maunsell JHR, Nealey TP, DePriest DD (1990) Magnocellular and parvocellular contributions to responses in the middle temporal visual area (MT) of the macaque monkey. *J Neurosci* 10:3323-3334.
- May JG, Andersen RA (1986) Different patterns of corticopontine projections from separate cortical fields within the inferior parietal lobule and dorsal prelunate gyrus of the macaque. *Exp Brain Res* 63:265-278.
- Merigan WH, Katz LM, Maunsell JHR (1991) The effects of parvocellular lateral geniculate lesions on the acuity and contrast sensitivity of macaque monkeys. *J Neurosci*, in press.
- Merzenich MM, Brugge JF (1973) Representation of the cochlear partition on the superior temporal plane of the macaque monkey. *Brain Res* 50:275-296.
- Merzenich MM, Kaas JH, Sur M, Lin C-S (1978) Double representation of the body surface within cytoarchitectonic areas 3b and 1 in "SI" in the owl monkey (*Aotus trivirgatus*). *J Comp Neurol* 181:41-74.
- Mesulam M-M, Van Hoesen GW, Pandya DN, Geshwind N (1977) Limbic and sensory connections of the inferior parietal lobule (area PG) in the rhesus monkey: a study with a new method for horseradish peroxidase histochemistry. *Brain Res* 136:393-414.
- Miller MW, Vogt BA (1984) Direct connections of rat visual cortex with sensory, motor, and association cortices. *J Comp Neurol* 226:184-202.
- Moran J, Desimone R (1985) Selective attention gates visual information processing in the extrastriate cortex. *Science* 229:782-784.
- Movshon JA, Adelson EH, Gizzi MS, Newsome WT (1986) The analysis of moving visual patterns. In: *Pattern recognition mechanisms* (Chagas C, Gattas R, Gross C, eds), pp 117-151. New York: Springer.
- Muakkassa KF, Strick PL (1979) Frontal lobe inputs to primate motor cortex: evidence for four somatotopically organized 'premotor' areas. *Brain Res* 177:176-182.
- Neal JW, Pearson RCA, Powell TPS (1987) The corticocortical connections of area 7b, PF, in the parietal lobe of the monkey. *Brain Res* 419:341-346.
- Newsome WT, Maunsell JHR, Van Essen DC (1986) The ventral posterior visual area of the macaque: visual topography and areal boundaries. *J Comp Neurol* 252:139-153.
- Newsome WT, Wurtz RH, Komatsu H (1988) Relation of cortical areas MT and MST to pursuit eye movements. II. Differentiation of retinal from extraretinal inputs. *J Neurophysiol* 60:604-620.
- Ogren MP, Hendrickson AE (1977) The distribution of pulvinar terminals in visual areas 17 and 18 of the monkey. *Brain Res* 137:343-350.
- Olavarria J, Montero VM (1984) Relation of callosal and striate-extrastriate cortical connections in the rat: morphological definition of extrastriate visual areas. *Exp Brain Res* 54:240-252.
- Olavarria J and Montero VM (1989) Organization of visual cortex in the mouse revealed by correlating callosal and striate-extrastriate connections. *Vis Neurosci* 3:56-69.
- Olavarria J, Van Sluyters RC (1985) Unfolding and flattening the cortex of gyrencephalic brains. *J Neurosci Meth* 15:191-202.
- Perkel DJ, Bullier J, Kennedy H (1986) Topography of the afferent connectivity of area 17 in the macaque monkey: a double-labelling study. *J Comp Neurol* 253:374-402.
- Perrett DI, Mistlin AJ, Chitty AJ (1987) Visual neurones responsive to faces. *Trends Neurosci* 10:358-364.
- Peterhans E, von der Heydt R (1989) Mechanisms of contour perception in monkey visual cortex. II. Contour bridging gaps. *J Neurosci* 9:1749-1763.
- Poggio GF, Fischer B (1977) Binocular interaction and depth sensitivity in striate and prestriate cortex of behaving rhesus monkey. *J Neurophysiol* 40:1392-1405.
- Pons TP, Kaas JH (1986) Corticocortical connections of area 2 of somatosensory cortex in macaque monkeys: a correlative anatomical and electrophysiological study. *J Comp Neurol* 248:313-335.
- Primrose DC, Strick PL (1985) The organization of interconnections between the premotor areas in the primate frontal lobe and the arm area of primary motor cortex. *Soc Neurosci Abstr* 11:1274.

- Purpura K, Kaplan E, Shapley RM (1988) Background light and the contrast gain of primate P and M retinal ganglion cells. *Proc Natl Acad Sci USA* 85:4534-4537.
- Rezak M, Benevento LA (1979) A comparison of the organization of the projections of the dorsal lateral geniculate nucleus, the inferior pulvinar and adjacent lateral pulvinar to primary visual cortex (area 17) in the macaque monkey. *Brain Res* 167:19-40.
- Robinson CJ, Burton H (1980) Organization of somatosensory receptive fields in cortical areas 7b, retroinsula, postauditory and granular insula of *M. fascicularis*. *J Comp Neurol* 192:69-92.
- Rockland KS (1985) A reticular pattern of intrinsic connections in primate area V2 (area 18). *J Comp Neurol* 235:467-478.
- Rockland KS, Pandya DN (1979) Laminar origins and terminations of cortical connections of the occipital lobe in the rhesus monkey. *Brain Res* 179:3-20.
- Rosenquist AC (1985) Connections of visual cortical areas in the cat. In: *Cerebral cortex, Vol 3* (Peters A and Jones EG, eds), pp 81-117. New York: Plenum.
- Saito H, Yuki M, Tanaka K, Kikosaka K, Fukada Y, Iwai E (1986) Integration of direction signals of image motion in the superior temporal sulcus of the macaque monkey. *J Neurosci* 6:145-157.
- Saito H, Tanaka K, Fukumoto M, Fukada Y (1987) The inferior temporal cortex of the macaque monkey: II. The level of complexity in the integration of pattern information. *Soc Neurosci Abstr* 13:177.17.
- Sanides F (1970) Functional architecture of motor and sensory cortices in primates in the light of a new concept of neocortex evolution. In: *The primate brain* (Noback CR and Montagna W, eds), pp 137-208. New York: Appleton-Century-Crofts.
- Saunders RC, Rosene DL (1988) A comparison of the efferents of the amygdala and the hippocampal formation in the rhesus monkey: I. Convergence in the entorhinal, prorrhinal, and perirrhinal cortices. *J Comp Neurol* 271:153-184.
- Saunders RC, Rosene DL, Van Hoesen GW (1988) Comparison of the efferents of the amygdala and the hippocampal formation in the rhesus monkey: II. Reciprocal and non-reciprocal connections. *J Comp Neurol* 271:185-207.
- Schein SJ, Marrocco RT, DeMonasterio FM (1982) Is there a high concentration of color-selective cells in area V4 monkey visual cortex? *J Neurophysiol* 47:193.
- Schiller PH, Logothetis NK (1990) The color-opponent and broad-band channels of the primate visual system. *Trends Neurosci* 13:392-398.
- Schiller PH, Finlay BL, Volman SF (1976a) Quantitative studies of single-cell properties in monkey striate cortex. I. Spatiotemporal organization of receptive fields. *J Neurophysiol* 39:1288-1319.
- Schiller PH, Finlay BL, Volman SF (1976b) Quantitative studies of single-cell properties in monkey striate cortex. II. Orientation and ocular dominance. *J Neurophysiol* 39:1320-1333.
- Schiller PH, Finlay BL, Volman SF (1976c) Quantitative studies of single-cell properties in monkey striate cortex. III. Spatial frequency. *J Neurophysiol* 39:1334-1351.
- Schiller PH, Logothetis NK, Charles ER (1990) Functions of the color-opponent (C-O) and broadband (B-B) channels in vision. *Nature* 343:68-70.
- Schlag J, Schlag-Rey M (1987) Evidence for a supplementary eye field. *J Neurophysiol* 57:179-200.
- Schwartz ML, Goldman-Rakic PS (1984) Callosal and intrahemispheric connectivity of the prefrontal association cortex in rhesus monkey: relation between intraparietal and principal sulcal cortex. *J Comp Neurol* 226:403-420.
- Selemon LD, Goldman-Rakic PS (1988) Common cortical and subcortical targets of the dorsolateral prefrontal and posterior parietal cortices in the rhesus monkey: evidence for a distributed neural network subserving spatially guided behavior. *J Neurosci* 8:4049-4068.
- Seltzer B, Pandya DN (1976) Some cortical projections to the parahippocampal area in the rhesus monkey. *Exp Neurol* 50:146-160.
- Seltzer B, Pandya DN (1978) Afferent cortical connections and architectonics of the superior temporal sulcus and surrounding cortex in the rhesus monkey. *Brain Res* 149:1-24.
- Seltzer B, Pandya DN (1980) Converging visual and somatic sensory cortical input to the intraparietal sulcus of the rhesus monkey. *Brain Res* 192:339-351.
- Seltzer B, Pandya DN (1984) Further observations on parieto-temporal connections in the rhesus monkey. *Exp Brain Res* 55:301-312.
- Seltzer B, Pandya DN (1986) Posterior parietal projections to the intraparietal sulcus of the rhesus monkey. *Exp Brain Res* 62:459-469.
- Seltzer B, Pandya DN (1987) Post-rolandic cortical projections of the superior temporal sulcus in the rhesus monkey. *Soc Neurosci Abstr* 13:251.
- Seltzer B, Pandya DN (1989a) Frontal lobe connections of the superior temporal sulcus in the rhesus monkey. *J Comp Neurol* 281:97-113.
- Seltzer B, Pandya DN (1989b) Intrinsic connections and architectonics of the superior temporal sulcus in the rhesus monkey. *J Comp Neurol* 290:451-471.
- Sereno MI, Allman JM (1991) Cortical visual areas in mammals. In: *Neural basis of visual function* (Leventhal A, ed). London: McMillan.
- Shapley R (1990) Visual sensitivity and parallel retinocortical channels. *Annu Rev Psychol* 41:635-658.
- Shapley R, Perry VH (1986) Cat and monkey retinal ganglion cells and their visual functional roles. *Trends Neurosci* 9:229-235.
- Sherk H (1986) Location and connections of visual cortical areas in the cat's suprasylvian sulcus. *J Comp Neurol* 247:1-31.
- Shipp S, Zeki S (1985) Segregation of pathways leading from V2 to areas V4 and V5 of macaque monkey visual cortex. *Nature* 315:322-325.
- Shipp S, Zeki S (1989) The organization of connections between areas V5 and V2 in macaque monkey visual cortex. *Eur J Neurosci* 1:333-354.
- Shiwa T (1987) Corticocortical projections to the monkey temporal lobe with particular reference to the visual processing pathways. *Arch Ital Biol* 125:139-154.
- Stanton GB, Deng S-Y, Goldberg ME, McMullen NT (1989) Cytoarchitectural characteristic of the frontal eye fields in macaque monkeys. *J Comp Neurol* 282:415-427.
- Stone J, Dreher B, Leventhal A (1979) Hierarchical and parallel mechanisms in the organization of visual cortex. *Brain Res Rev* 1:345-394.
- Sur M, Wall JT, Kaas JH (1981) Modular segregation of functional cell classes within the postcentral somatosensory cortex of monkeys. *Science* 212:1059-1061.
- Suzuki WA, Amaral DG (1990) Cortical inputs to the CA1 field of the monkey hippocampus originate from the perirhinal and parahippocampal cortex but not from area TE. *Neurosci Lett* 115:43-48.
- Swanson LW, Köhler C, Björklund A (1987) The limbic region. I: The septo-hippocampal system. In: *Handbook of chemical neuroanatomy, Vol 5* (Björklund A, Hökfelt T, and Swanson LM, eds), pp 125-276. New York: Elsevier.
- Symonds LL, Rosenquist AC (1984a) Corticocortical connections among visual areas in the cat. *J Comp Neurol* 229:1-38.
- Symonds LL, Rosenquist AC (1984b) Laminar origins of visual cortico-cortical connections in the cat. *J Comp Neurol* 229:39-47.
- Tigges J, Tigges M (1985) Subcortical sources of direct projections to visual cortex. In: *Cerebral cortex, Vol 3* (Peters A and Jones EG, eds), pp 351-378. New York: Plenum.
- Tigges J, Spatz WB, Tigges M (1973) Reciprocal point-to-point connections between parastriate and striate cortex

- in the squirrel monkey (*Saimiri*). *J Comp Neurol* 148: 481.
- Tigges J, Tigges M, Ansel S, Cross N, Letbetter WD, McBride RL (1981) Areal and laminar distribution of neurons interconnecting the central visual cortical areas 17, 18, 19, and MT in squirrel monkey (*Saimiri*). *J Comp Neurol* 202:539.
- Tootell RB and Silverman MS (1985) Two methods for flat-mounting cortical tissue. *J Neurosci Meth* 15:177-190.
- Turner BH, Gupta KC, Mishkin M (1978) The locus and cytoarchitecture of the projection areas of the olfactory bulb in *Macaca mulatta*. *J Comp Neurol* 177:381-396.
- Turner BH, Mishkin M, Knapp M (1980) Organization of the amygdalopetal projections from modality-specific cortical association areas in the monkey. *J Comp Neurol* 191:515-543.
- Ungerleider LG, Desimone R (1986a) Projections to the superior temporal sulcus from the central and peripheral field representations of V1 and V2. *J Comp Neurol* 248: 147-163.
- Ungerleider LG, Desimone R (1986b) Cortical connections of visual area MT in the macaque. *J Comp Neurol* 248:190-222.
- Ungerleider LG, Mishkin M (1982) Two cortical visual systems. In: *Analysis of visual behavior* (Ingle DG, Goodale MA, and Mansfield RJQ, eds), pp 549-586. Cambridge, MA: MIT Press.
- Ungerleider LG, Gattass R, Sousa APB, Mishkin M (1983) Projections of area V2 in the macaque. *Soc Neurosci Abstr* 9:152.
- Van Essen DC (1985) Functional organization of primate visual cortex. In: *Cerebral cortex, Vol 3* (Peters A and Jones EG, eds), pp 259-329. New York: Plenum.
- Van Essen DC, Anderson CH (1990) Information processing strategies and pathways in the primate retina and visual cortex. In: *Introduction to neural and electronic networks* (Zornetzer SF, Davis JF, and Lau C, eds), pp 43-72. Orlando: Academic.
- Van Essen DC, Maunsell JHR (1980) Two-dimensional maps of the cerebral cortex. *J Comp Neurol* 191:255-281.
- Van Essen DC, Maunsell JHR (1983) Hierarchical organization and functional streams in the visual cortex. *Trends Neurosci* 6:370-375.
- Van Essen DC, Zeki SM (1978) The topographic organization of rhesus monkey prestriate cortex. *J Physiol (Lond)* 277:193-226.
- Van Essen DC, Maunsell JHR, Bixby JL (1981) The middle temporal visual area in the macaque: myeloarchitecture, connections, functional properties and topographic organization. *J Comp Neurol* 199:293-326.
- Van Essen DC, Newsome WT, Bixby JL (1982) The pattern of interhemispheric connections and its relationship to extrastriate visual areas in the macaque monkey. *J Neurosci* 2:265-283.
- Van Essen DC, Newsome WT, Maunsell JHR (1984) The visual field representation in striate cortex of the macaque monkey: asymmetries, anisotropies and individual variability. *Vision Res* 24:429-448.
- Van Essen DC, Newsome WT, Maunsell JHR, Bixby JL (1986) The projections from striate cortex (V1) to areas V2 and V3 in the macaque monkey: asymmetries, areal boundaries, and patchy connections. *J Comp Neurol* 224: 451-480.
- Van Essen DC, DeYoe EA, Olavarria JF, Knierim JJ, Fox JM, Sagi D, Julesz B (1989) Neural responses to static and moving texture patterns in visual cortex of the macaque monkey. In: *Neural mechanisms of visual perception* (Lam DM-K and Gilbert CD, eds), pp 137-154. Woodlands, TX: Portfolio.
- Van Essen DC, Felleman DF, DeYoe EA, Olavarria J, Knierim JJ (1991) Modular and hierarchical organization of extrastriate visual cortex in the macaque monkey. *Cold Spring Harbor Symp Quant Biol*, Vol 55, in press.
- Van Hoesen GW, Pandya DN (1975) Some connections of the entorhinal (area 28) and perirhinal (area 35) cortices of the rhesus monkey. I. Temporal lobe afferents. *Brain Res* 95:1-24.
- Vogt BA, Pandya DN (1978) Cortico-cortical connections of somatic sensory cortex (areas 3, 1 and 2) in the rhesus monkey. *J Comp Neurol* 177:179-192.
- Von Bonin G, Bailey P (1947) *The neocortex of Macaca mulatta*. Urbana: University of Illinois Press.
- Von der Heydt R, Peterhans E (1989) Mechanisms of contour perception in monkey visual cortex. I. Lines of pattern discontinuity. *J Neurosci* 9:1731-1748.
- Walker AE (1940) A cytoarchitectural study of the prefrontal areas of the macaque monkey. *J Comp Neurol* 73: 59-86.
- Weller RE, Kaas JH (1987) Subdivisions and connections of inferior temporal cortex in owl monkeys. *J Comp Neurol* 256:137-172.
- Yeterian EH, Pandya DN (1985) Corticothalamic connections of the posterior parietal cortex in the rhesus monkey. *J Comp Neurol* 237:408-426.
- Yukie M, Iwai E (1985) Laminar origin of direct projection from cortex area V1 to V4 in the rhesus monkey. *Brain Res* 346:383-386.
- Yukie M, Iwai E (1988) Direct projections from the ventral TE area of the infero-temporal cortex to hippocampal field CA1 in the monkey. *Neurosci Lett* 88:6-10.
- Yukie M, Niida T, Suyama H, Iwai E (1988) Interaction of visual cortical areas with the hippocampus in monkeys. *Neuroscience* 14:297-302.
- Zeki SM (1978a) The cortical projections of foveal striate cortex in the rhesus monkey. *J Physiol (Lond)* 277:227-244.
- Zeki SM (1978b) Uniformity and diversity of structure and function in rhesus monkey prestriate visual cortex. *J Physiol (Lond)* 277:273-290.
- Zeki SM (1980) A direct projection from area V1 to area V3A of rhesus monkey visual cortex. *Proc R Soc Lond [Biol]* 207:499-506.
- Zeki SM (1983) Color coding in the cerebral cortex: the reaction of cells in monkey visual cortex to wavelengths and color. *Neuroscience* 9:741-765.
- Zeki SM, Shipp S (1988) The functional logic of cortical connections. *Nature* 335:311-317.
- Zeki SM, Shipp S (1989) Modular connections between areas V2 and V4 of macaque monkey visual cortex. *Eur J Neurosci* 1:494-506.